

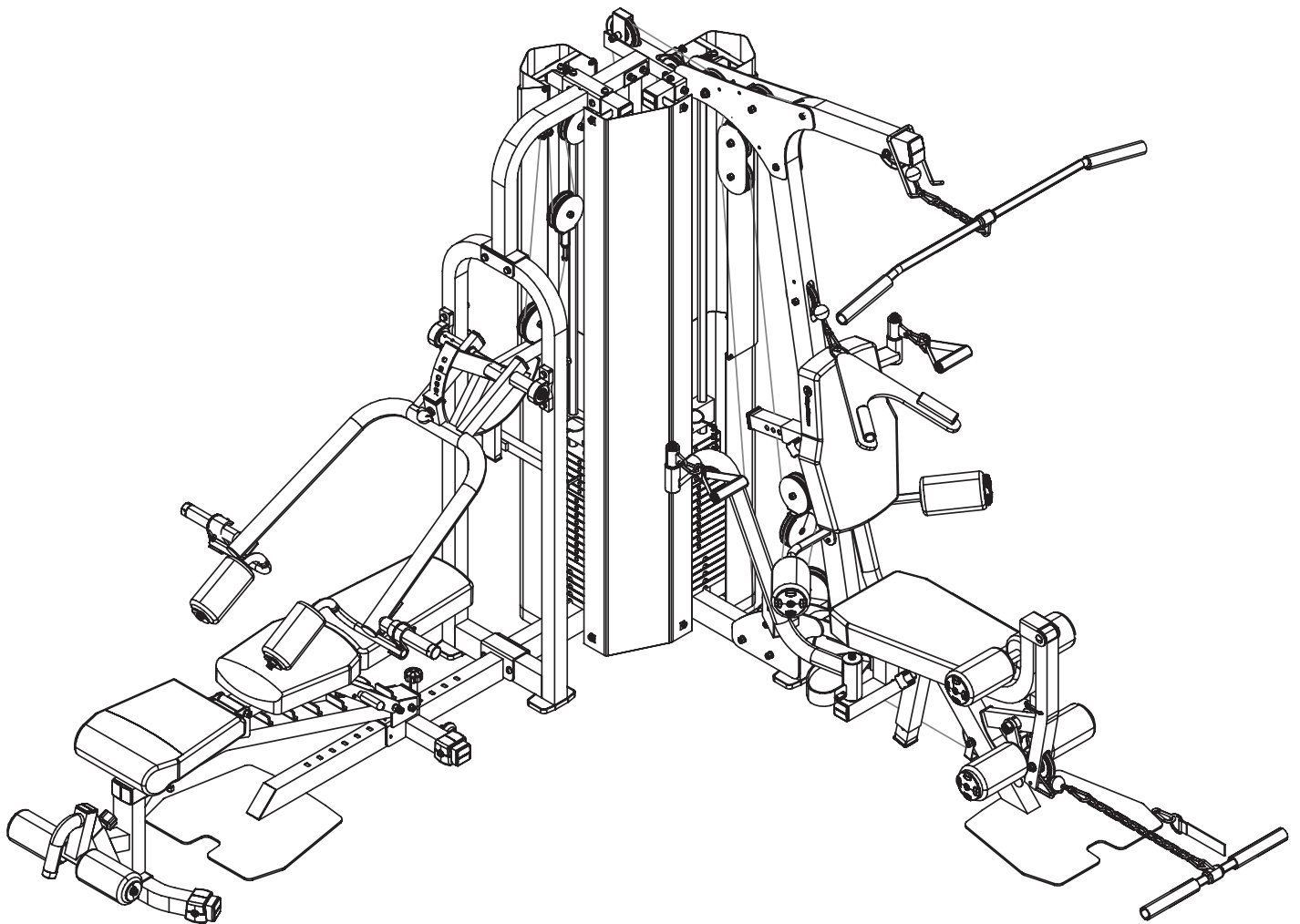

KeysFitness®

Owner's Manual

KF-2060



215-00132
11/06 Rev A



Before You Start	3
Important Safety Information	4
Assembly	5-40
Weight Ratios	41
Weight Stack Sticker Placement	42
Cable View	43
Top View	44
Exploded View	45
Parts List	46
Warranty Information	47



THANK YOU for making this unit a part of your exercise program. Keys Fitness assures the very best in value, appearance, durability and biomechanics.

This manual will guide you through the assembly process. If at any time you are having trouble with the assembly or use of this product, then please contact us at our Keys Fitness Helpline. We have trained service technicians on site to take care of you, our valued customer.

REGISTRATION CARD

To avoid unnecessary delays in warranty parts and to insure that a permanent record of your purchase is on file with our company, be sure to send in the warranty registration card or register on-line at www.keysfitness.com within 10 days of purchase.

KEYS FITNESS SERIES

QUESTIONS?

CALL

1-888-380-0482

Monday-Friday

8:30-5:30 Central Time

When calling please have the following product information available:

Model Name : KF-2060

Serial #:

Manufactured Date :

PO # :

Model Name Decal Location

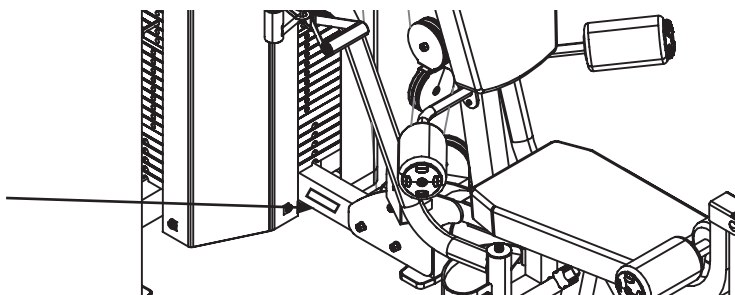

Prior to assembly, remove components from the box and verify that all the listed parts were supplied.

NOTE: Hand tighten bolts and nylon nuts until machine is fully assembled.

! CAUTION

Read all precautions and instructions in this manual before using this equipment.

WARNING!

Before using this unit or starting any exercise program, consult your physician. This is especially important for persons over the age of 35 and/or persons with pre-existing health problems. Keys Fitness Products LP assumes no responsibility for personal injury or property damage sustained by or through the use of this product.

It is the owner's responsibility to ensure that all users of this unit have read the Owner's Manual and are familiar with safety information and precautions.

SAFETY PRECAUTIONS

- This unit should only be used on a level surface and is intended for indoor use only. Keys Fitness recommends an equipment mat be placed under the unit to protect the floor or carpet and for easier cleaning.
- Wear comfortable, good-quality walking or running shoes and appropriate clothing. Do not use this unit with bare feet, sandals, socks or stockings!
- Always examine your unit before using to ensure all parts are in working order.
- Do not leave children unsupervised near or on the unit.
- Service to your unit should only be performed by an authorized service representative, unless authorized and/or instructed by a Keys Fitness technician. Failure to follow these instructions will void the warranty.

Box 1



【 3 】 1pc

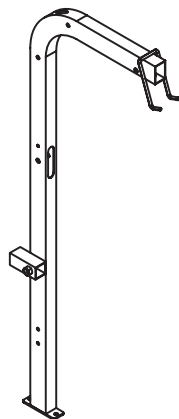

【 7 】 1pc

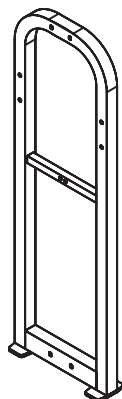

【 10 】 1pc



【 47 】 4pcs

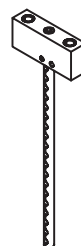

【 55 】 2pcs

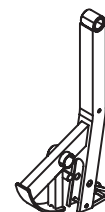

【 20 】 1pc

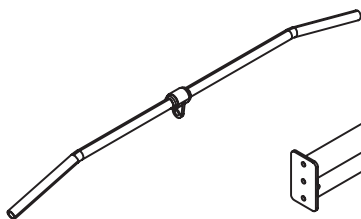

【 43 】 1pc

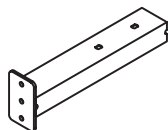

【 4 】 1pc

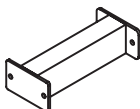

【 8 】 1pc

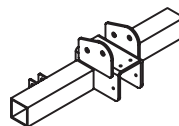

【 15 】 1pc

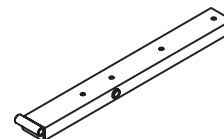

【 17 】 1pc

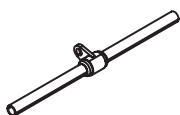

【 44 】 1pc



【 57 】 19pcs



【 59 】 1pc

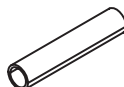

【 63 】 4pcs



【 76 】 1pc



【 104 】 2pcs



【 105 】 4pcs



【 78 】 2pcs



【 80 】 2pcs



【 92 】 1pc



【 93 】 1pc



【 100 】 1pc



【 120 】 2pcs



【 109 】 2pcs



【 79 】 2pcs



【 94 】 2pcs



【 153 】 2pcs



【 106 】 14pcs

Box 2

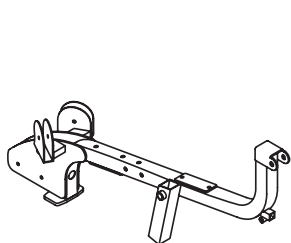

【6】 1pc

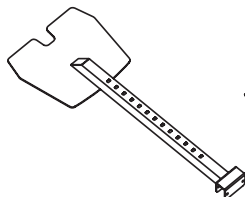

【11】 1pc

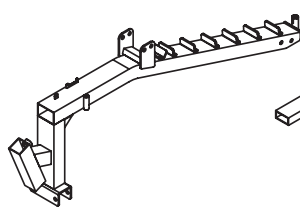

【13】 1pc

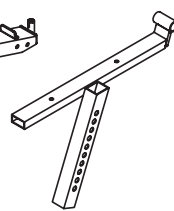

【27】 1pc

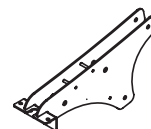

【5】 1pc

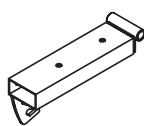

【16】 1pc



【18】 1pc

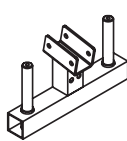

【21】 1pc



【39】 1pc



【24】 2pcs

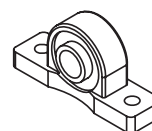

【75】 2pcs

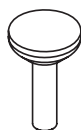

【45】 1pc



【59】 1pc



【21】 1pc

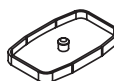

【80】 1pc



【76】 1pc



【68】 1pc



【82】 1pc



【71】 1pc

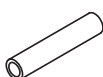

【70】 1pc



【69】 1pc

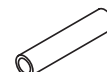

【72】 2pcs



【67】 2pcs



【92】 1pc



【93】 1pc



【94】 2pcs



【95】 3pcs



【96】 2pcs



【107】 1pc

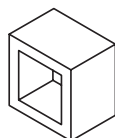

【81】 1pc



【104】 1pc



【105】 1pc



【83】 1pc

Box 3

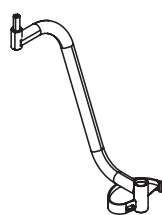

【22】 1pc

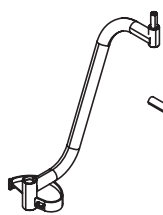

【23】 1pc

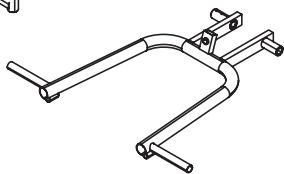

【35】 1pc

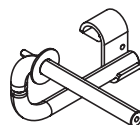

【37】 1pc

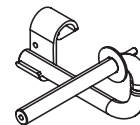

【36】 1pc

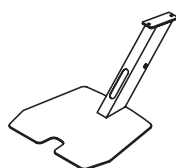

【19】 1pc



【30】 1pc



【29】 1pc



【40】 1pc



【38】 1pc

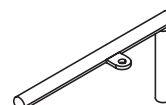

【64】 1pc



【116】 1pc



【56】 2pcs

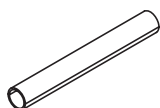

【72】 2pcs



【73】 1pc



【74】 1pc



【88】 1pcs



【87】 7pcs



【46】 2pcs



【66】 1pc



【124】 1pc



【86】 1pc



【85】 1pc



【121】 6pcs



【122】 2pcs



【123】 8pcs



【110】 1pc



【111】 1pc



【113】 1pc



【112】 1pc



【114】 1pc



【115】 1pc



【146】 1pc



【147】 1pc



【148】 1pc



【107】 2pcs



【99】 4pcs



【89】 6pcs



【90】 8pcs



【91】 2pcs



【96】 3pcs



【107】 2pcs



【102】 2pcs



【77】 4pcs



【161】 1pc



【162】 1pc



【163】 1pc

Box 4

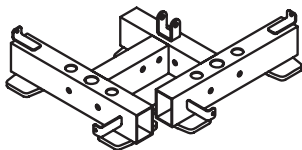

【1】 1pc

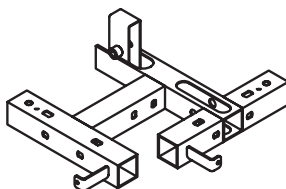

【2】 1pc

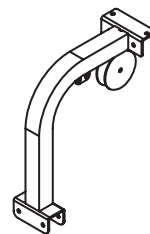

【9】 1pc

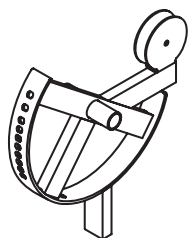

【12】 1pc

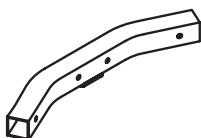

【14】 1pc

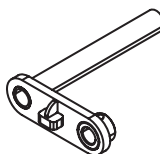

【25】 1pc

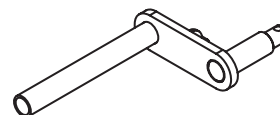

【26】 1pc

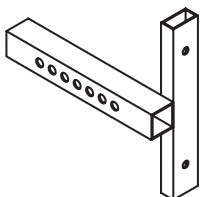

【28】 1pc



【32】 1pc

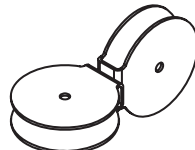

【31】 1pc

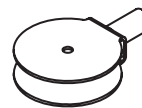

【33】 2pcs

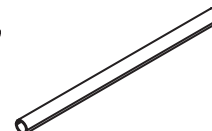

【34】 1pc

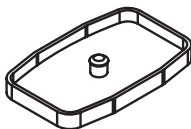

【80】 5pcs



【93】 5pcs



【95】 1pc



【96】 4pcs



【104】 2pcs



【108】 2pcs

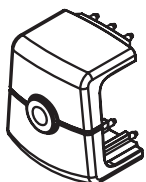

【79】 2pcs

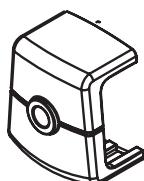

【153】 2pcs

Box 5

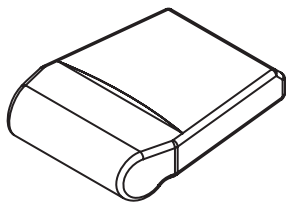

【48】 1pc

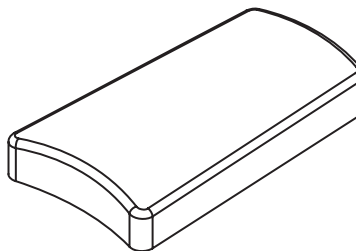

【49】 1pc

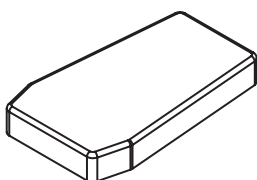

【50】 1pc



【51】 1pc

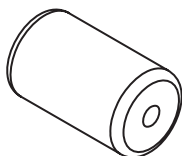

【58】 10pcs

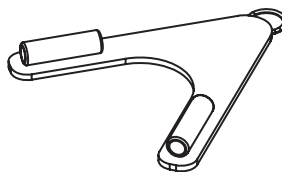

【60】 1pc

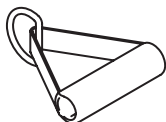

【61】 2pcs



【62】 1pc

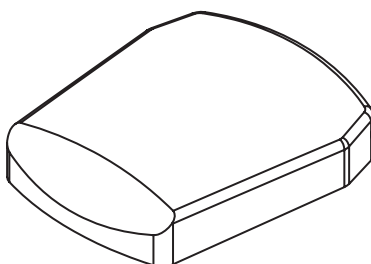

【156】 2pcs

Box 6

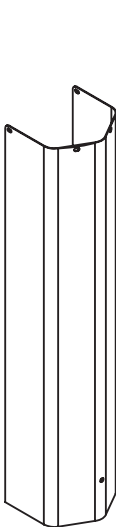

【41】 2pcs

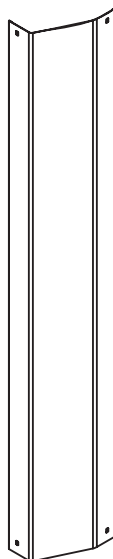

【42】 1pc

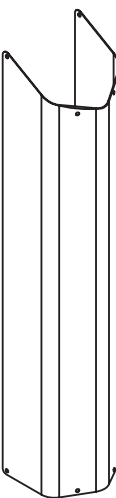

【157】 2pcs

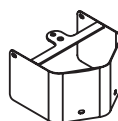

【145】 2pcs



【158】 16pcs

Box 7

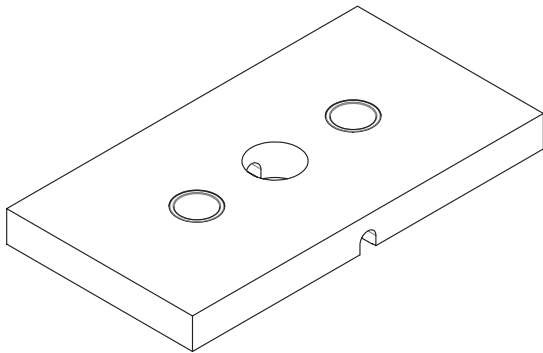

【52】 5pcs

Box 8

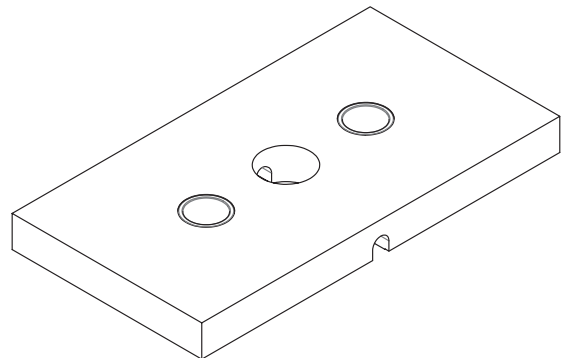

【52】 5pcs

Box 9

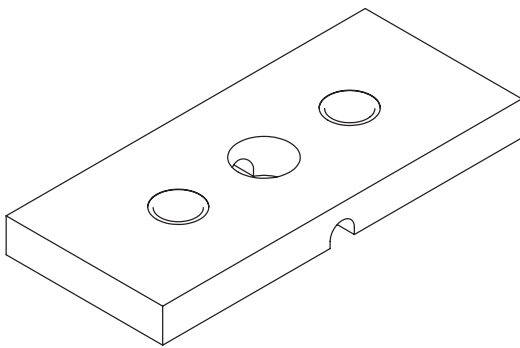

【53】 9pcs

Box 10

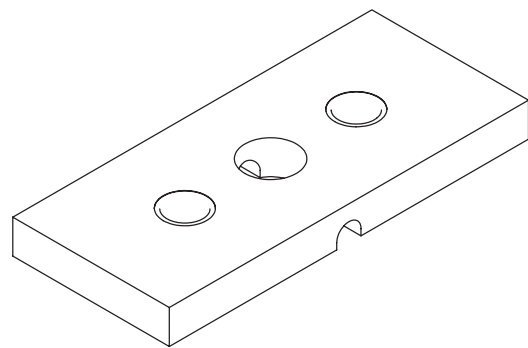

【53】 9pcs

Box 11

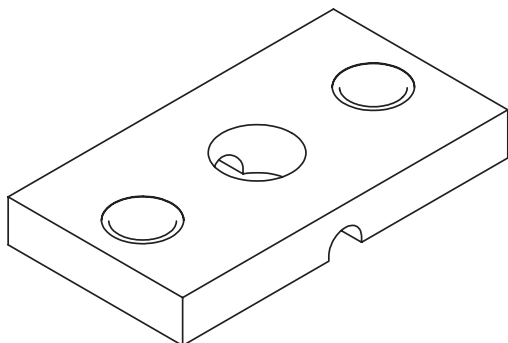

【54】 5pcs

Box 12

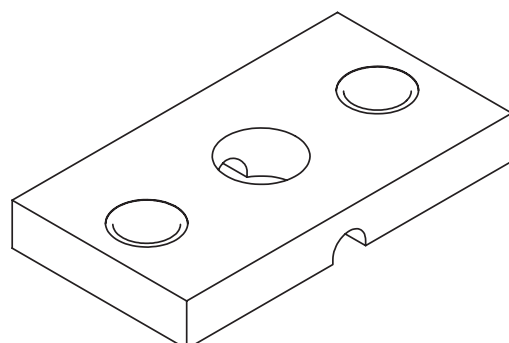

【54】 5pcs

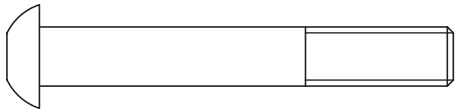

[137#] M10*70 11pcs

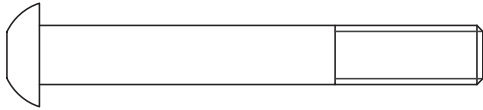

[136#] M10*75 12pcs

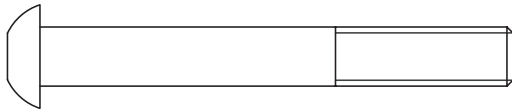

[135#] M10*80 7pcs

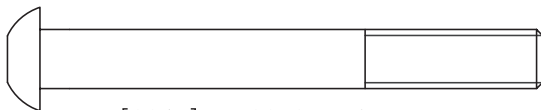

[134#] M10*85 6pcs

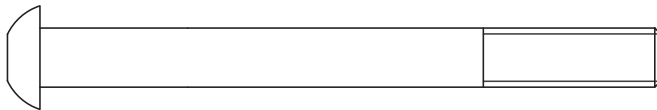

[133#] M10*105 2pcs

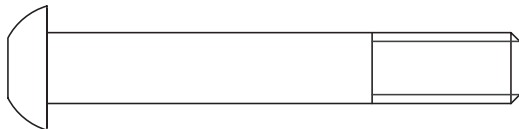

[131#] M12*80 4pcs

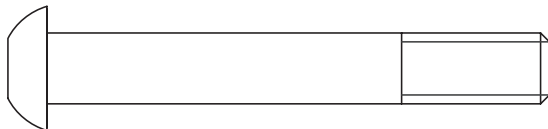

[130#] M12*85 4pcs

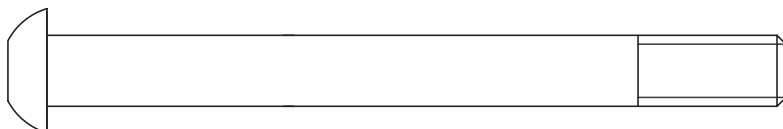

[132#] M12*125 4pcs

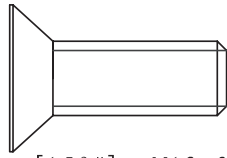

[150#] M12*35 2pcs

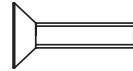

[103#] M4*20 2pcs

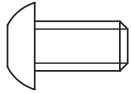

[98#] M8*15 9pcs



[97#] M8*6 3pcs

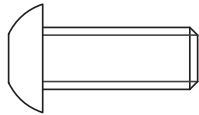

[128#] M10*25 12pcs



[140#] 10-32*3.2 6pcs

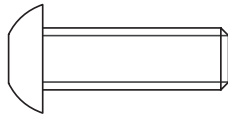

[142#] M10*30 4pcs

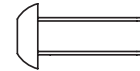

[159#] M6*18 16pcs

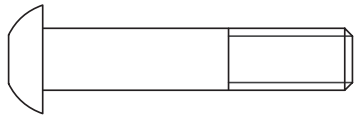

[127#] M10*50 4pcs



[160#] $\varnothing 6.6 * \varnothing 12 * 1.6$ 32

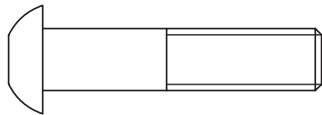

[141#] M10*45 12pcs



[118#] $\varnothing 8$ 1pc

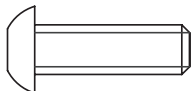

[154#] M8*25 8pcs

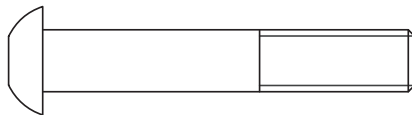

[139#] M10*60 1pc

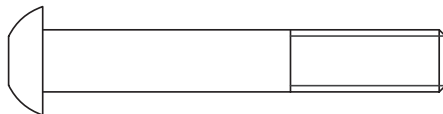

[138#] M10*65 7pcs



[155#] $\varnothing 9 * \varnothing 16 * 1.6$ 8pcs

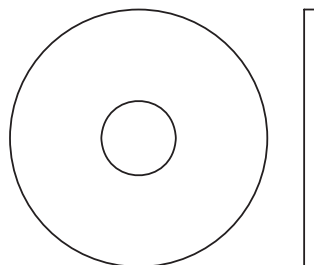

[101#] $\varnothing 38 * \varnothing 11 * 2$ 2pcs

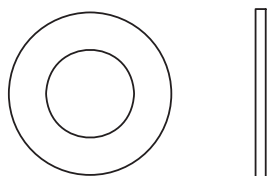

[125#] $\varnothing 24 * \varnothing 13 * 1.5$ 25pcs

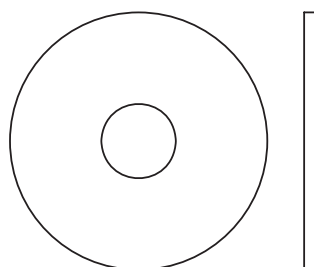

[129#] $\varnothing 38 * \varnothing 11 * 2$ 8pcs

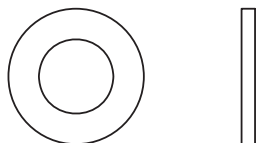

[143#] $\varnothing 20 * \varnothing 11 * 2$ 128pcs

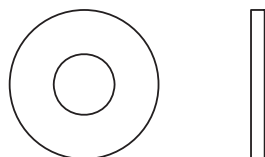

[117#] $\varnothing 22 * \varnothing 9 * 2$ 7pcs



[119#] $\varnothing 10$ 17pcs

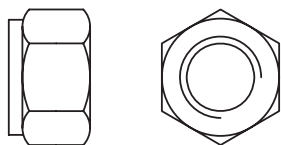

[126#] M12 13pcs

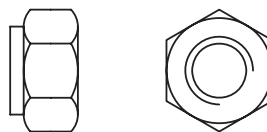

[144#] M10 52pcs

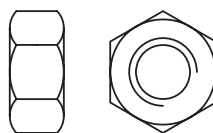

Step 1

Attach Right Base Frame (4) to Rear Frame (1) using two Nuts (144), four Washers (143), and two Bolts (137).

Attach Left Base Frame (8) to Rear Frame (1) using two Nuts (144), four Washers (143), and two Bolts (137).

Insert Guide Rods (47) into Rear Frame (1). Next, slide Weight Stack Bumpers (99) onto Guide Rods (47).

Attach Rear Upright (3) to Rear Frame (1) using two Nuts (144), four Washers (143), and two Bolts (136).

Figure 1

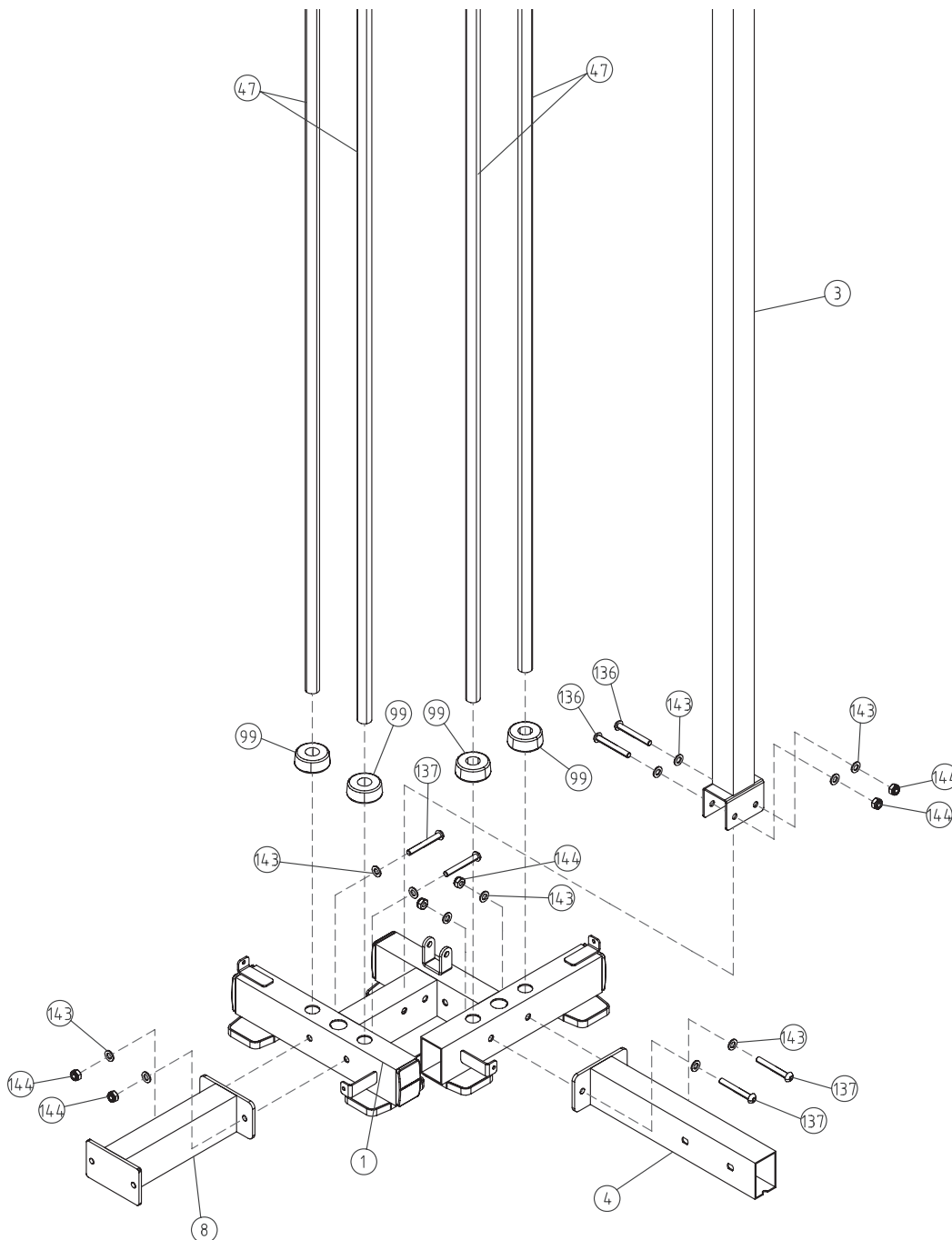

Step 2

Slide the weight plates down the Guide Rods (47) in this order - five 15lb Plates (52), nine 10lb Plates (53), five 5lb Plates (54), and the Top Plate (55). **Note:** Number of weight plates may vary depending on your specific configuration.

Attach Top Frame (2) to all four Guide Rods (47) and secure to Rear Upright (3) using two Nuts (144), four Washers (143), and two Bolts (136).

Figure 2

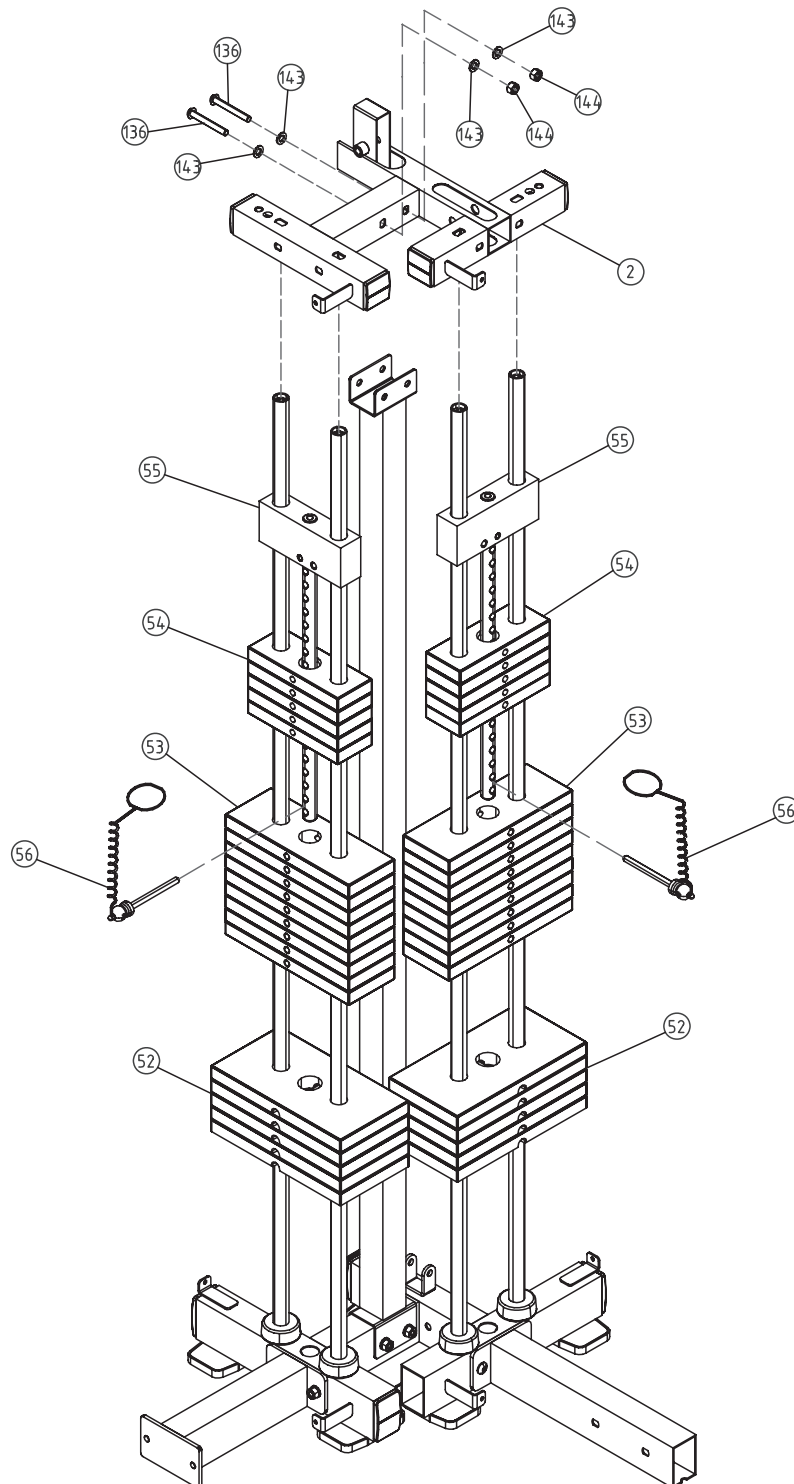

Step 3

Attach Front Upright (19) to Seat Pad Support Receptacle (6) using two Nuts (144), four Washers (143), and two Bolts (136).

Attach Seat Pad Support Receptacle (6) to Base Frame assembly using two Nuts (144), four Washers (143), and two Bolts (136).

Figure 3

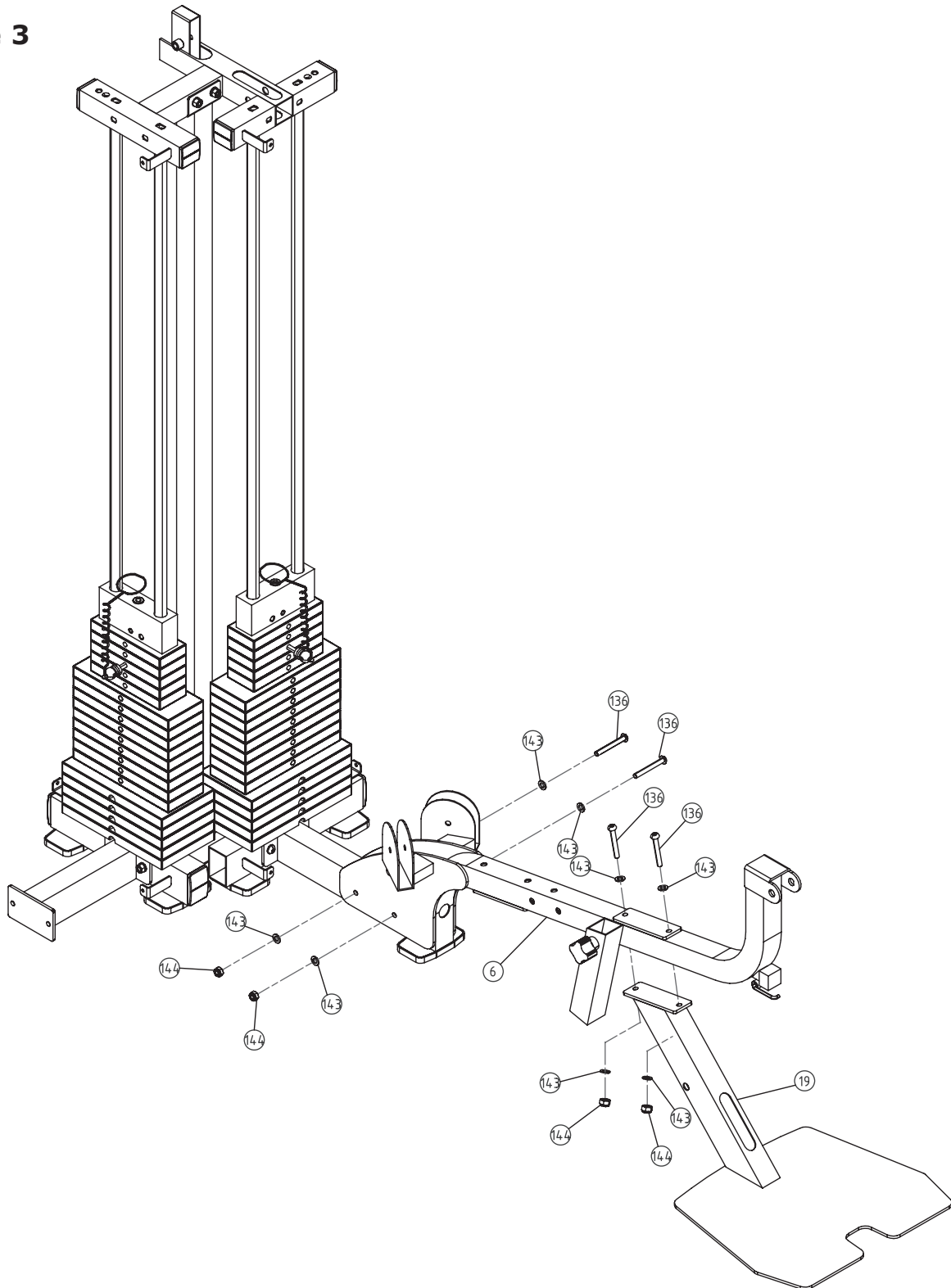

Step 4

Attach Main Upright (7) to Seat Pad Support Receptacle using two Nuts (126), four Washers (125), and two Bolts (131).

Attach Right Top Frame (5) to Top Frame assembly using two Nuts (144), four Washers (143), and two Bolts (137). Next, use two Washers (143), two Spring Washers (119), and two Bolts (142) to connect Right Top Frame (5) to Main Upright.

Figure 4

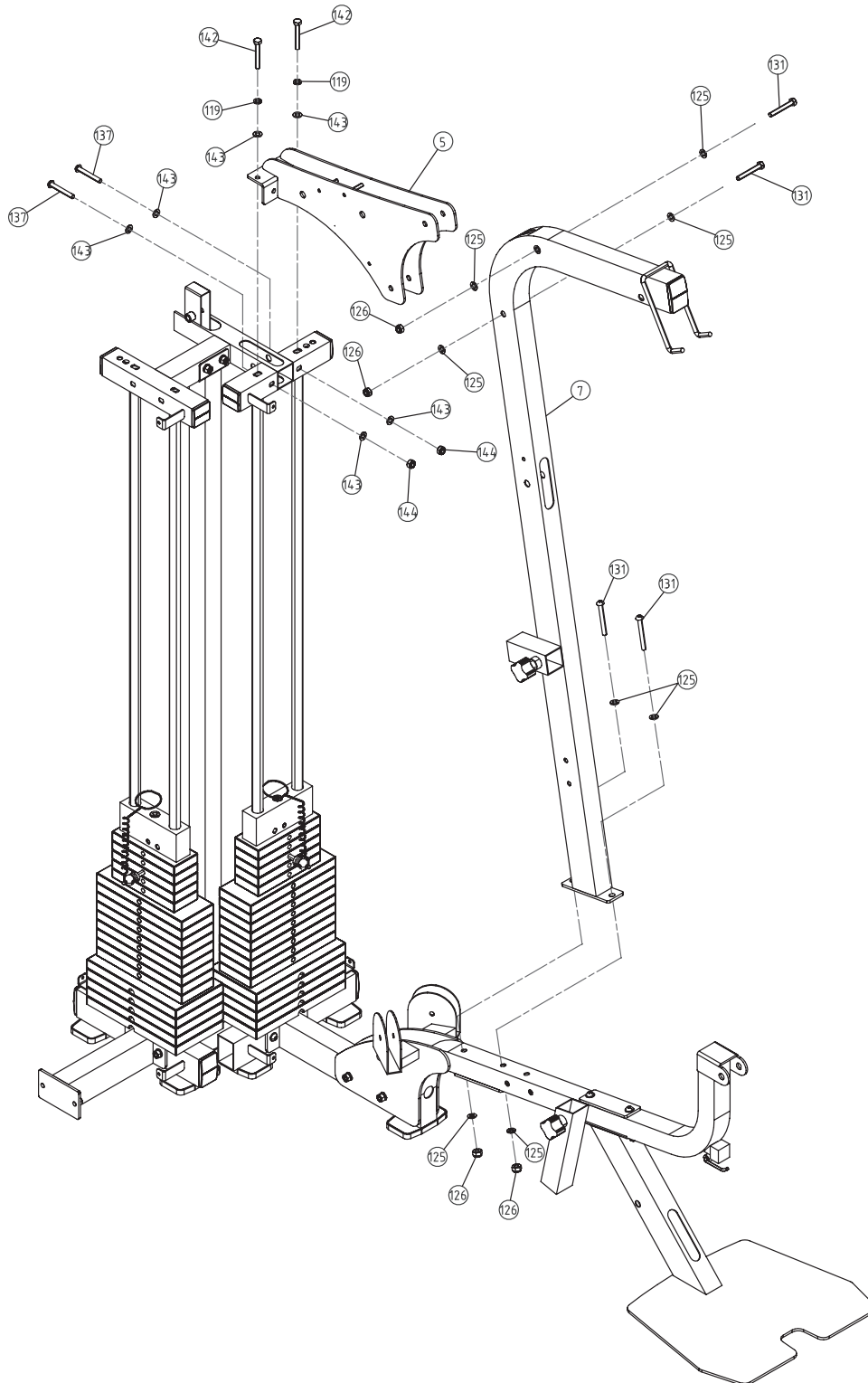

Step 5

Slide Press Station Base Frame (11) over Press Arm Support (10). Next, attach both pieces to Base Frame using two Nuts (144), four Washers (143), and two Bolts (134).

Install Left Top Frame over Press Arm Support (10) and Top Frame assembly. Secure top section using two Nuts (144), four Washers (143), and two Bolts (137). Next, Secure lower section using two Nuts (144), four Washers (143), and two Bolts (136). Secure top of Guide Rods (47) using two Washers (143), two Spring Washers (119), and two Bolts (142).

Figure 5

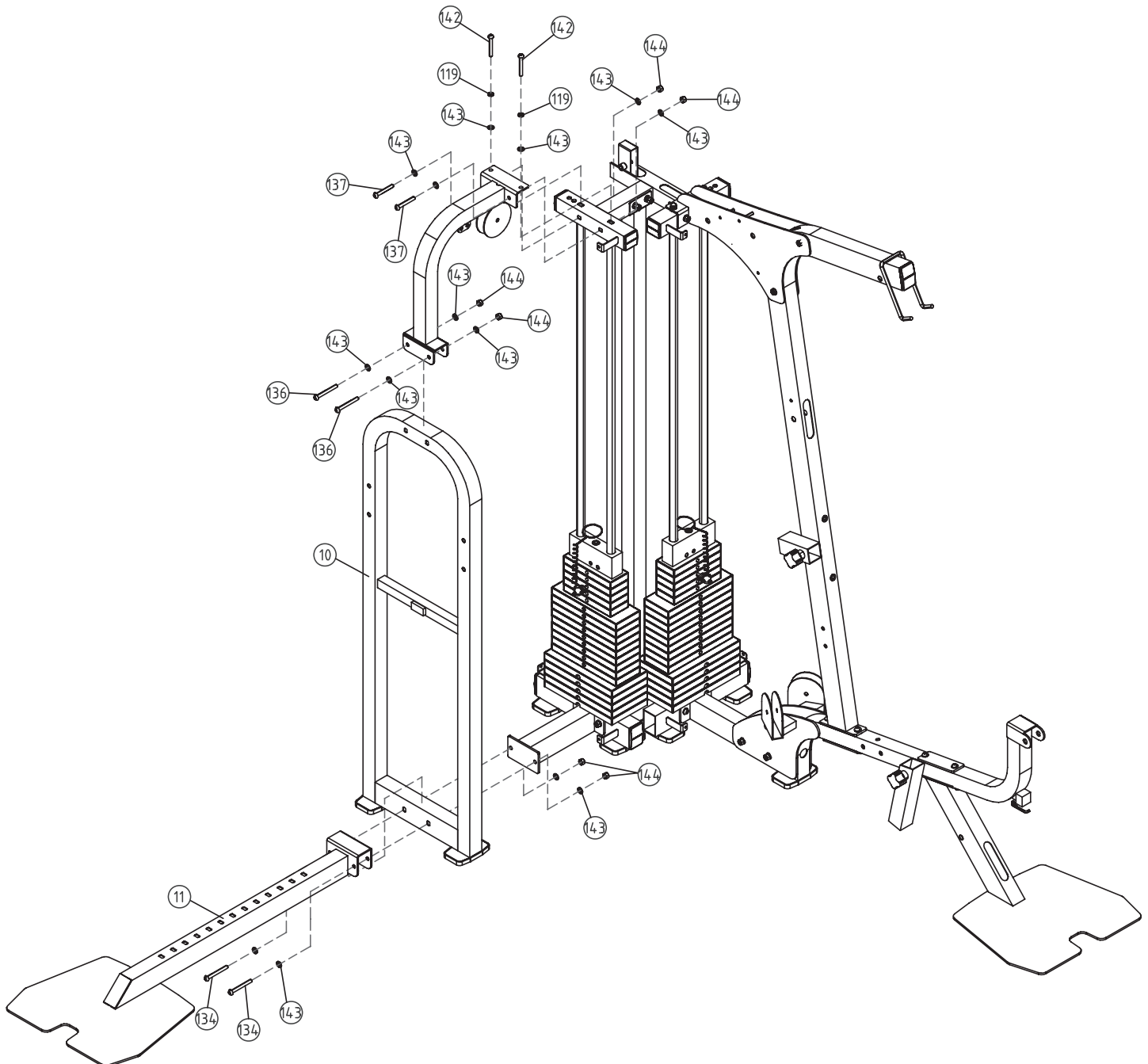

Step 6

Attach Pec Dec Mount (21) onto Seat Pad Support Receptacle using two Nuts (144), four Washers (143), and two Bolts (136). Secure in place with one Washer (129), one Spring Washer (119), and one Bolt (137).

Figure 6

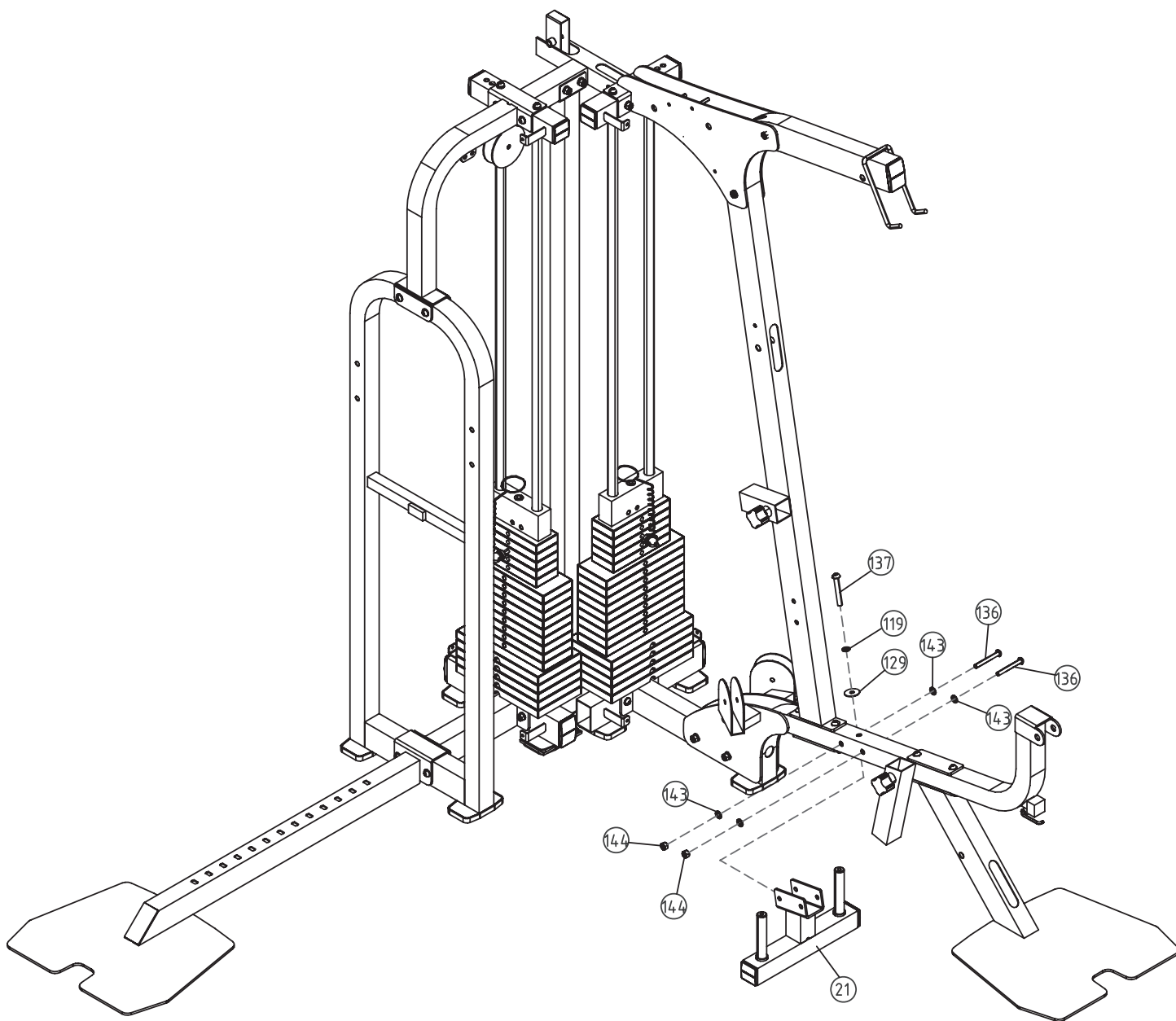

Step 7

Attach Right and Left Leg Hold Leg Frames (29 & 30) using two Nuts (144), four Washers (143), and two Bolts (135).

Figure 7

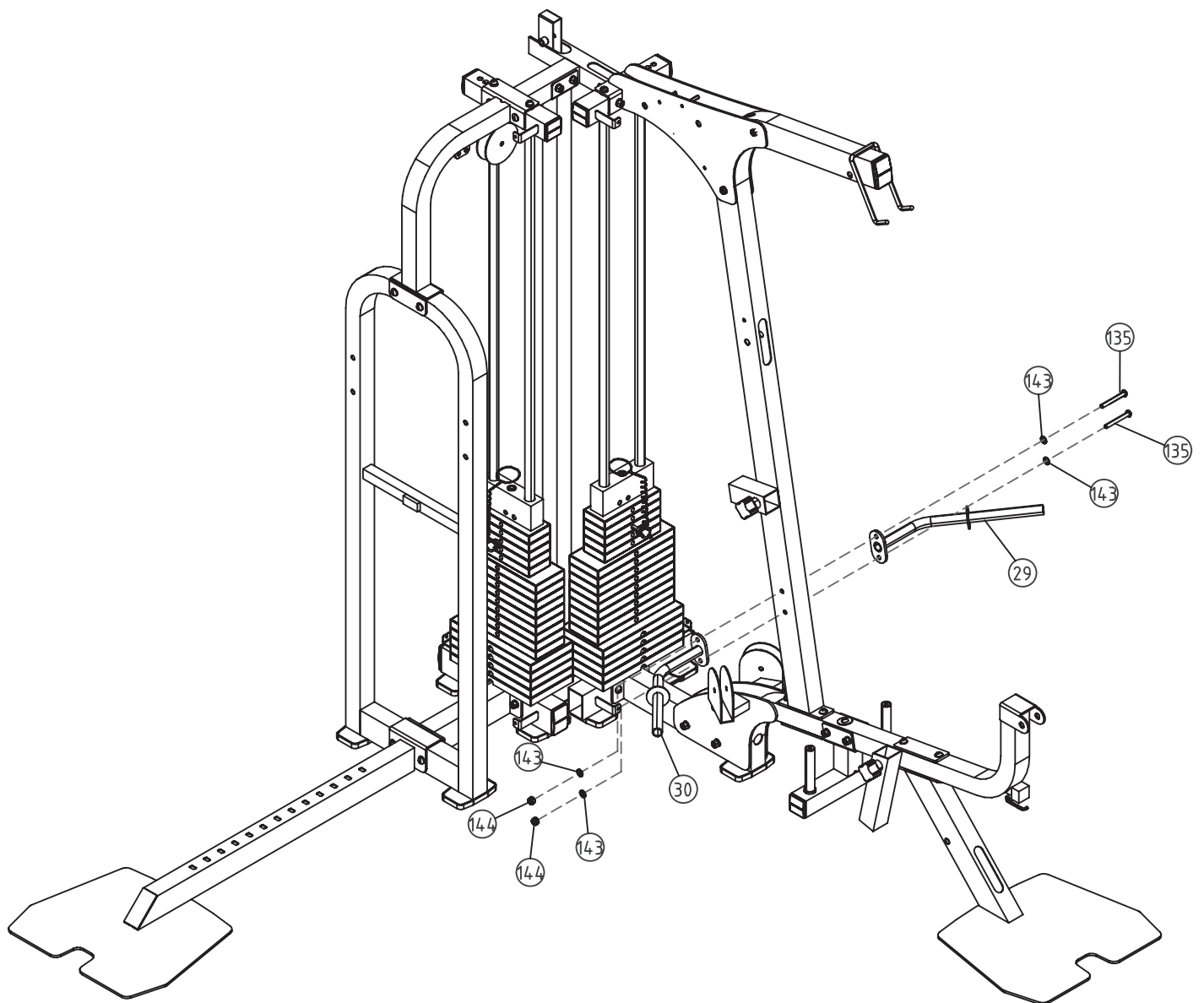

Step 8

Slide the Right Pec Dec Arm (22) on to the shaft of the Pec Dec Mount. Secure the arm in place using one Big Washer (102), one Washer (143), one Spring Washer (119), and one Bolt (128).

Slide Pec Dec Handle Bar (24) onto the top of the Right Pec Dec Arm (22) and secure using one Chrome Washer (101), one Washer (143), one Spring Washer (119), and one Bolt (128).

Repeat this step to complete the Left Pec Dec assembly.

Figure 8

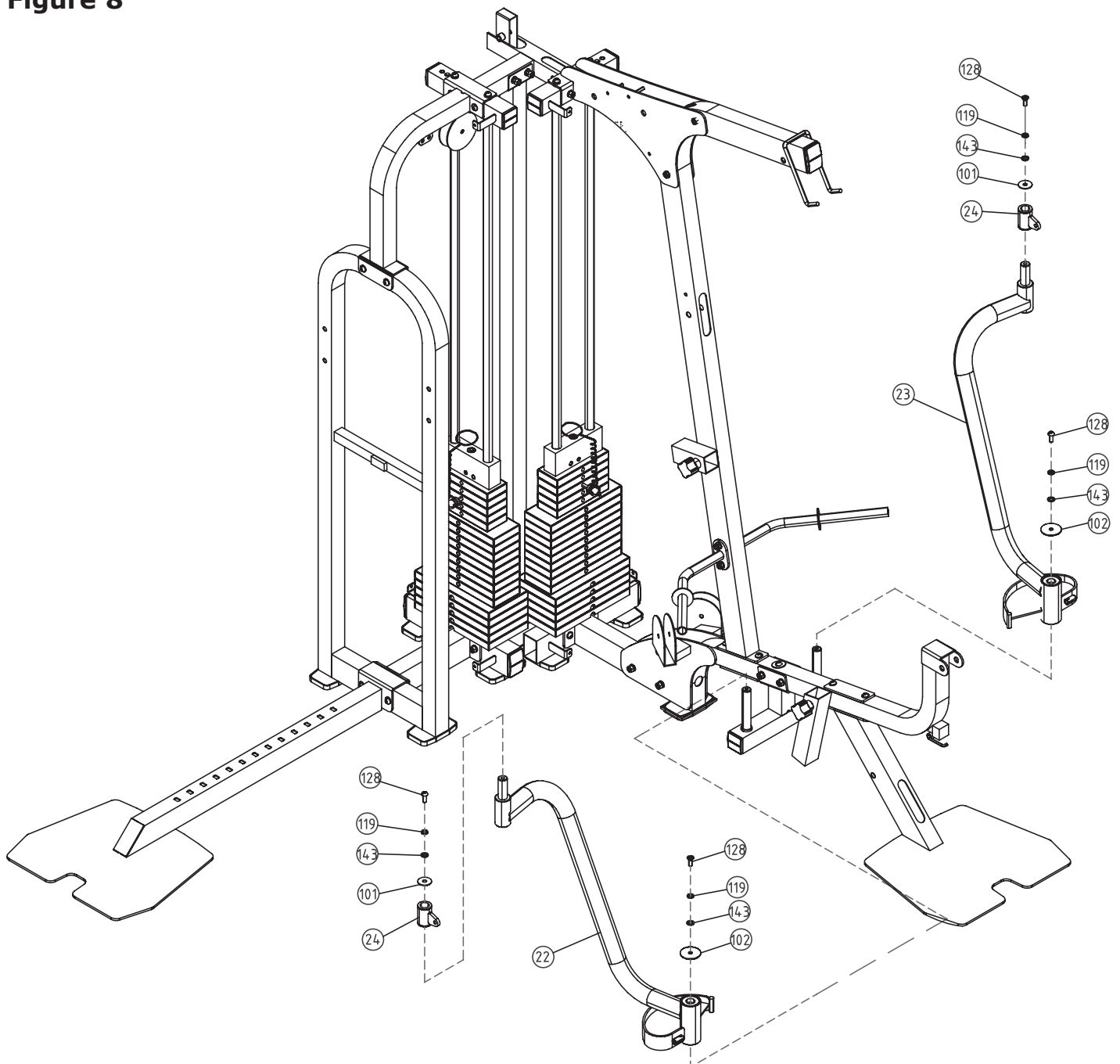

Step 9

Attach Leg Extension Lever (20) to Seat Pad Support Receptacle (6) and secure using Shaft (86), one Washer (117), one Spring Washer (118), and one Allen Bolt (98).

Slide Foam Frame w/ Shaft (26) through the Leg Extension Lever (20) and attach Foam Frame w/o Shaft (25) to the other side. Insert Slip Tension Pin (85) through the hole where the two foam frames meet.

Note: You may need to use a rubber mallet to install Slip Tension Pin (85).

Figure 9

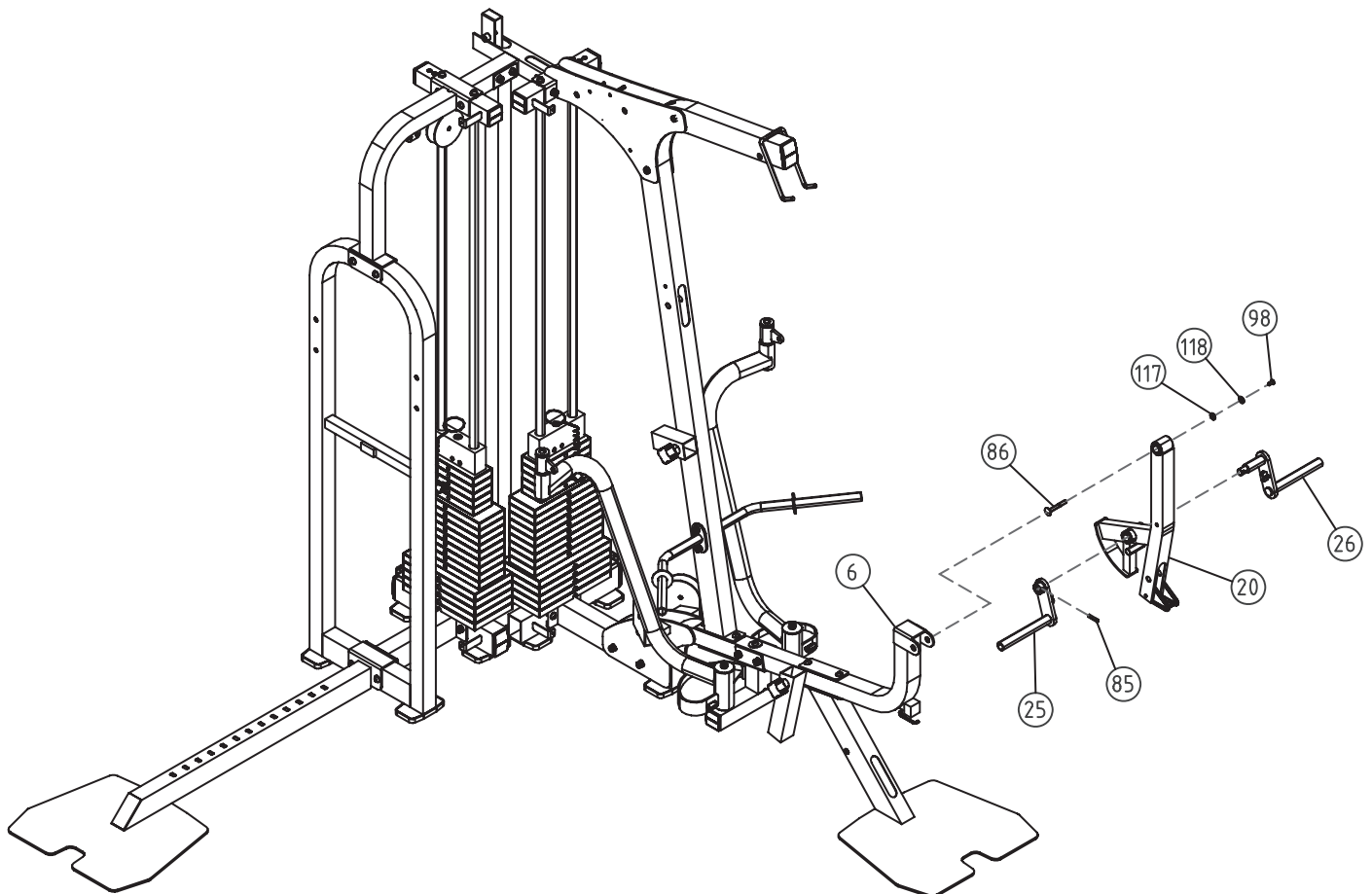

Step 10

Align Press Arm (35) and Chest Press Cam (12) while inserting Press Station Shaft (38). Slide Pillow Block Bearing (75) onto each side of Press Station Shaft (38) and secure the assembly using two Chrome Washers (101), two Washers (143), two Spring Washers (119), and two Allen Bolts (128).

Attach the entire assembly to Press Arm Support using four Nuts (126), eight Washers (125), and four Bolts (130).

Figure 10

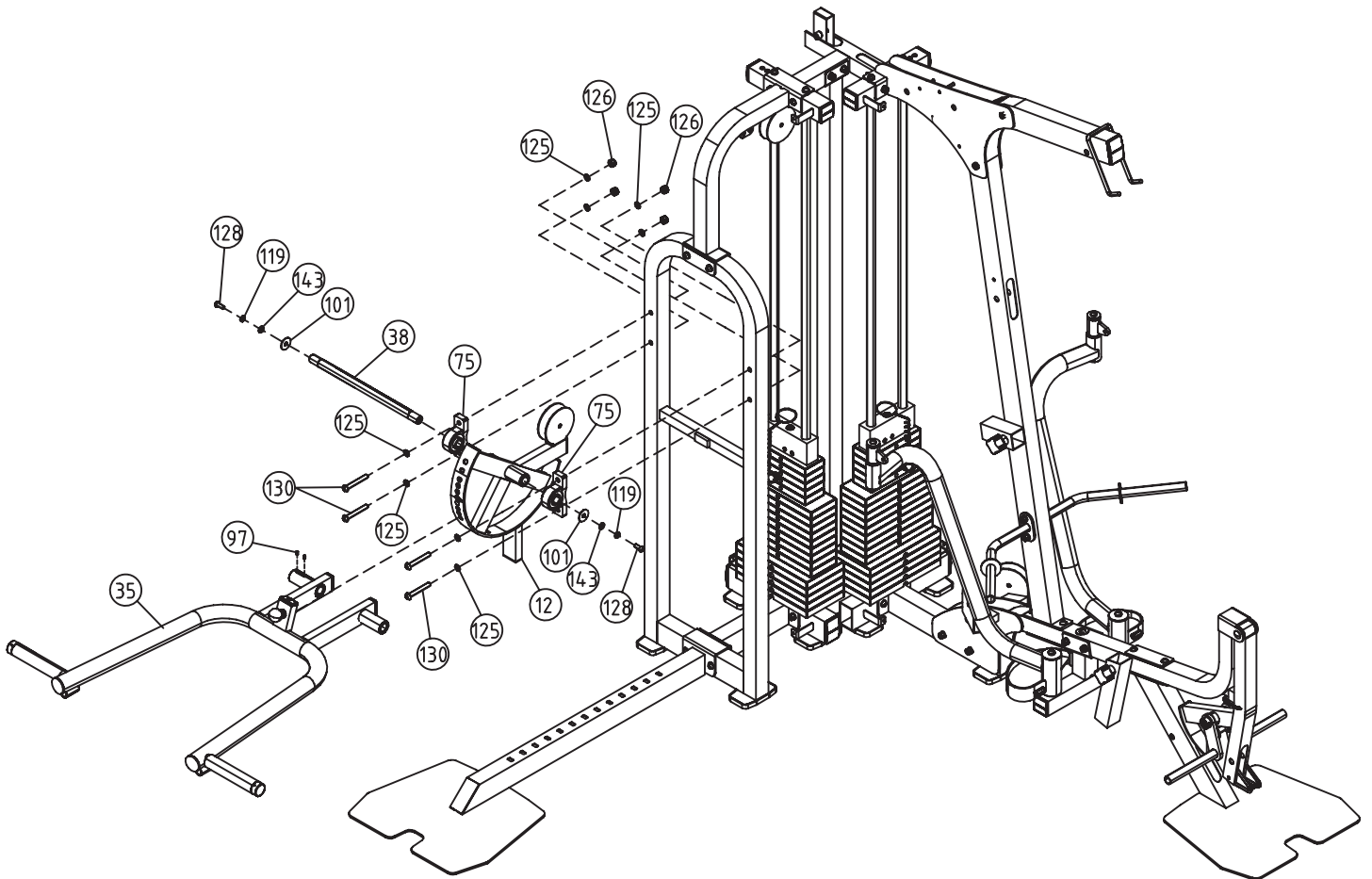

Step 11

Attach Bench Rear Frame (15) onto Bench Main Frame (13) and secure using two Nuts (144), four Washers (143), and two Bolts (133).

Attach Bench Front Stabilizer (14) on to Bench Main Frame (13) using two Nuts (144), four Washers (143), and two Bolts (136).

Figure 11

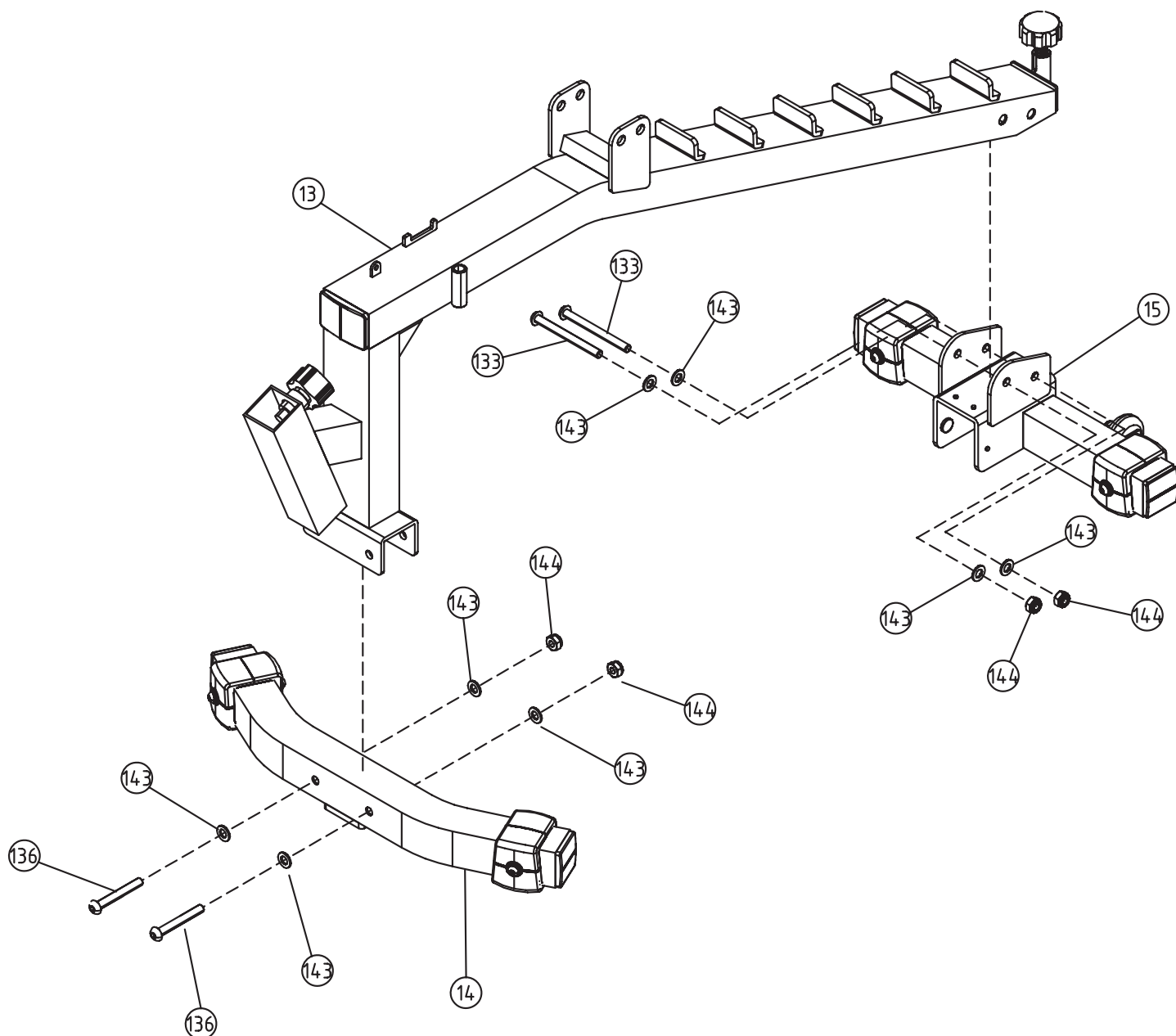

Step 12

Attach Bench Seat Pad Support (16) to Bench Main Frame using one Nut (126), two Washer (125), and one Bolt (132).

Insert Bench Seat Pad Adjustment Bar (64) into Bench Main Frame and secure using one Washer (125) and one Nut (126). Attach Spring (66) to Bench Main Frame and Bench Seat Pad Adjustment Bar (64).

Note: Make sure adjustment bar is installed into adjustable slots on Bench Seat Pad Support.

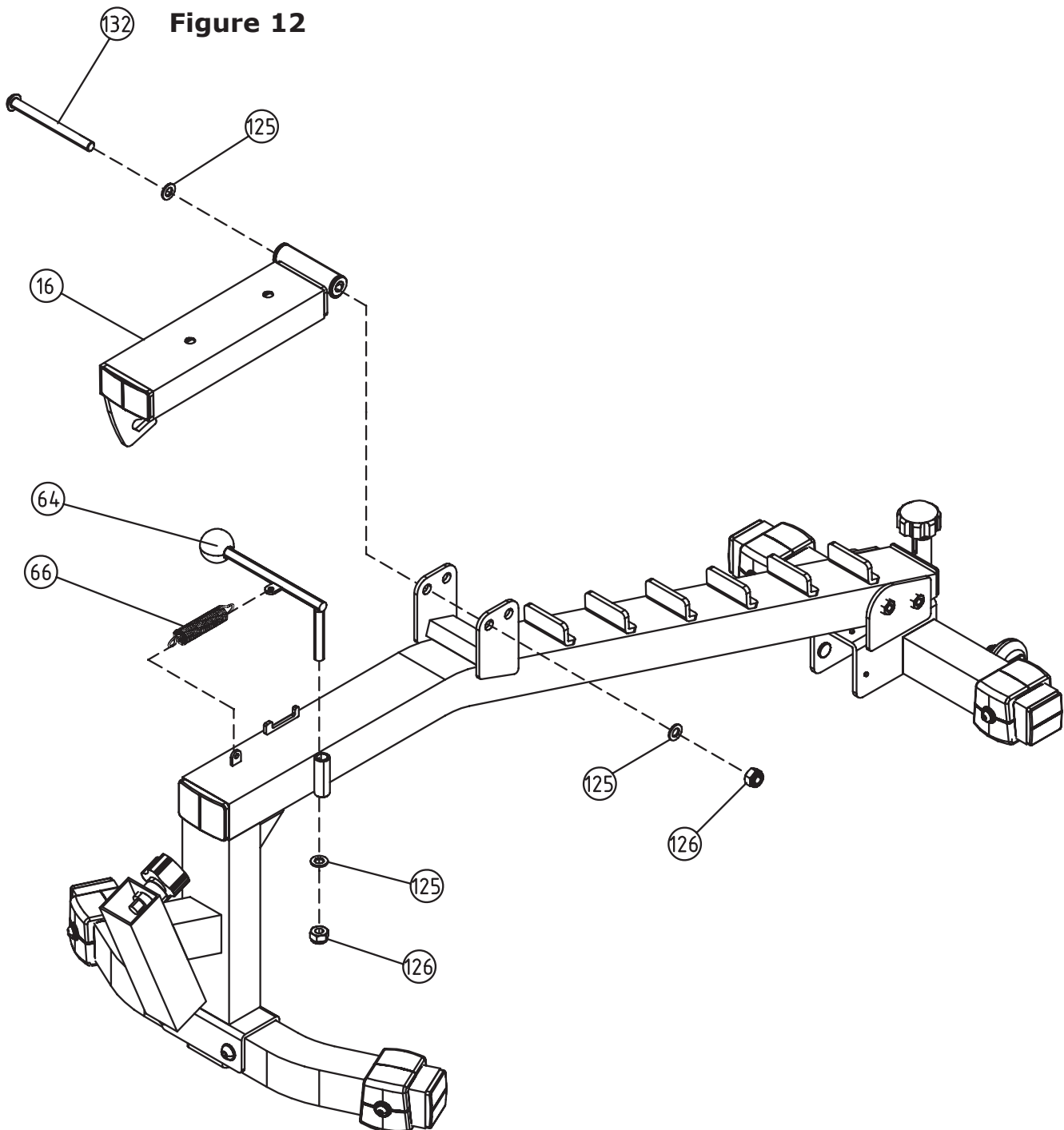

Step 13

Attach Bench Back Pad Support (17) to Bench Main Frame using one Nut (126), two Washers (125), and one Bolt (132).

Attach Bench Back Pad Adjustment Frame (39) to Bench Back Pad Support (17) using one Nut (126), two Washers (125), and one Bolt (132).

Figure 13

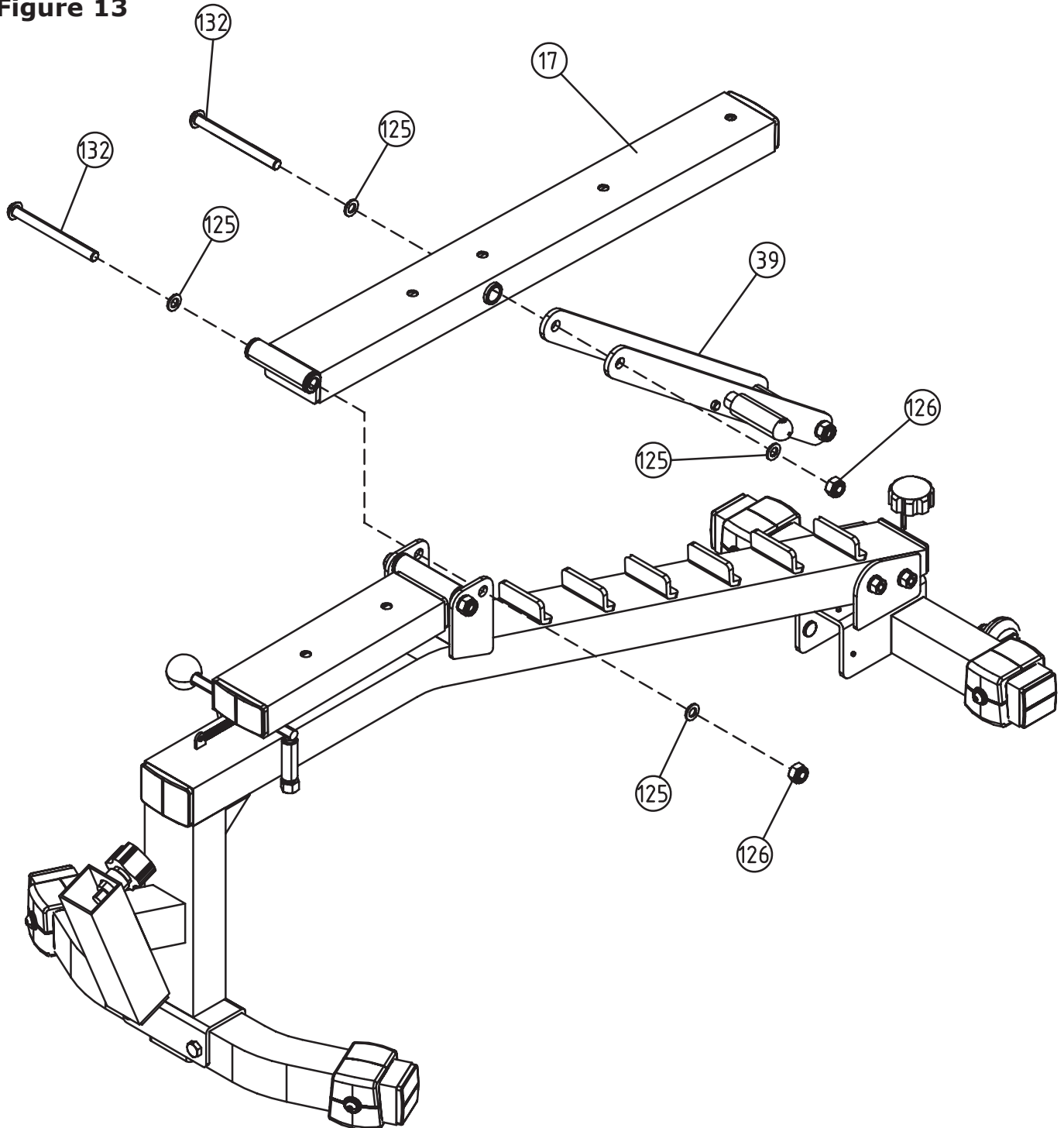

Step 14

Attach Bench Seat Pad (48), Bench Lower Back Pad (156) and Bench Back Pad (49) using six Washers (143) and six Bolts (138).

Insert Foam Shaft (40) into Foam Adjustable Bracket (18). Next, attach Upholstered Roller Pads (58) using the following hardware: four Plastic Washers (90), two Chrome Washers (101), two Washers (143), two Spring Washers (119), and two Bolts (128).

Figure 14

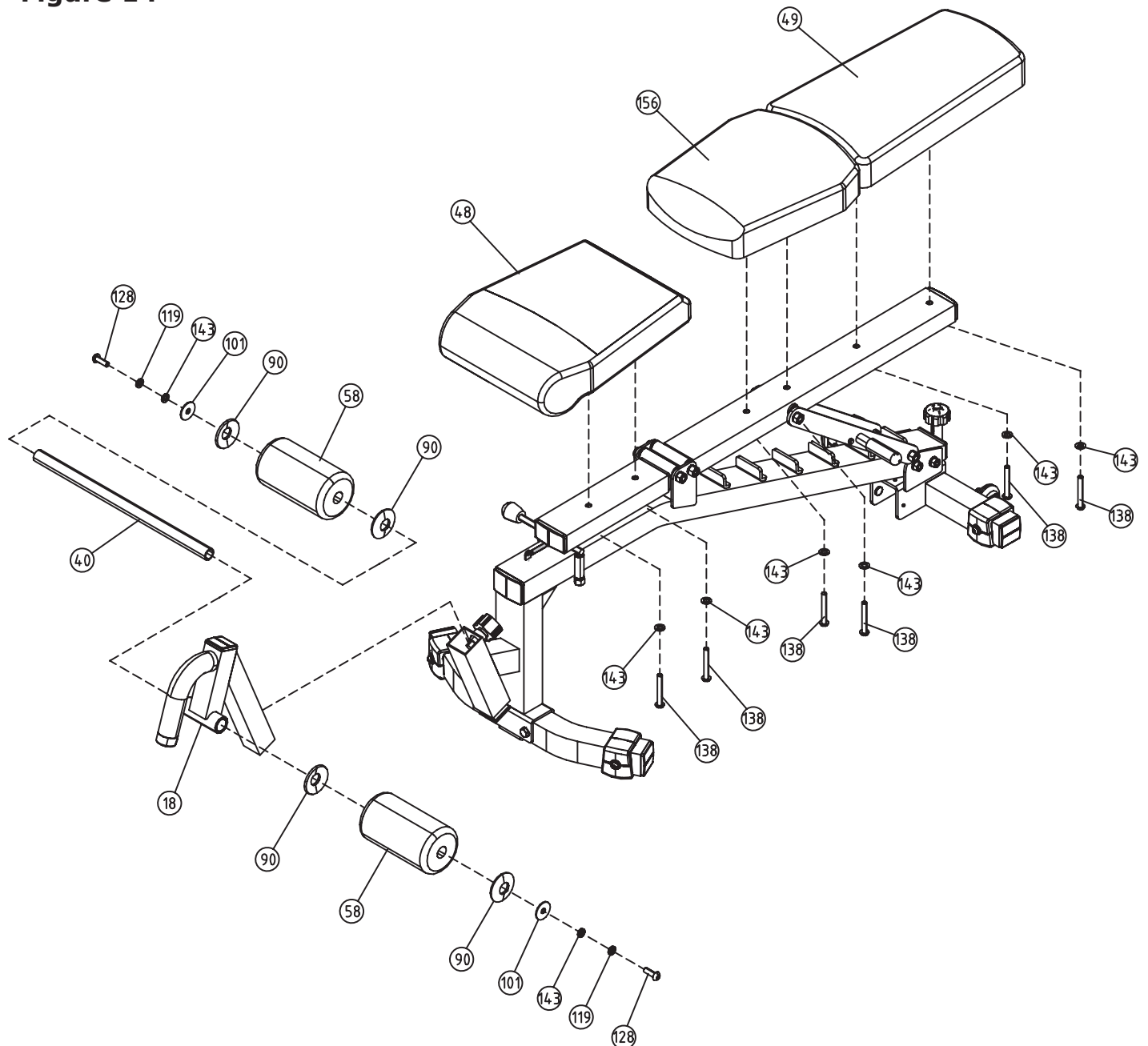

Step 15

Attach Left and Right Squat Arms (36 & 37) to the Press Arm Assembly (35) using two Safety Pins (73).

Next, slide Upholstered Roller Pad (58) onto each Squat Arm (36 & 37) and secure using two Plastic Washers (90), two Chrome Washers (101), two Washers (143), two Spring Washers (119), and two Bolts (128).

Figure 15

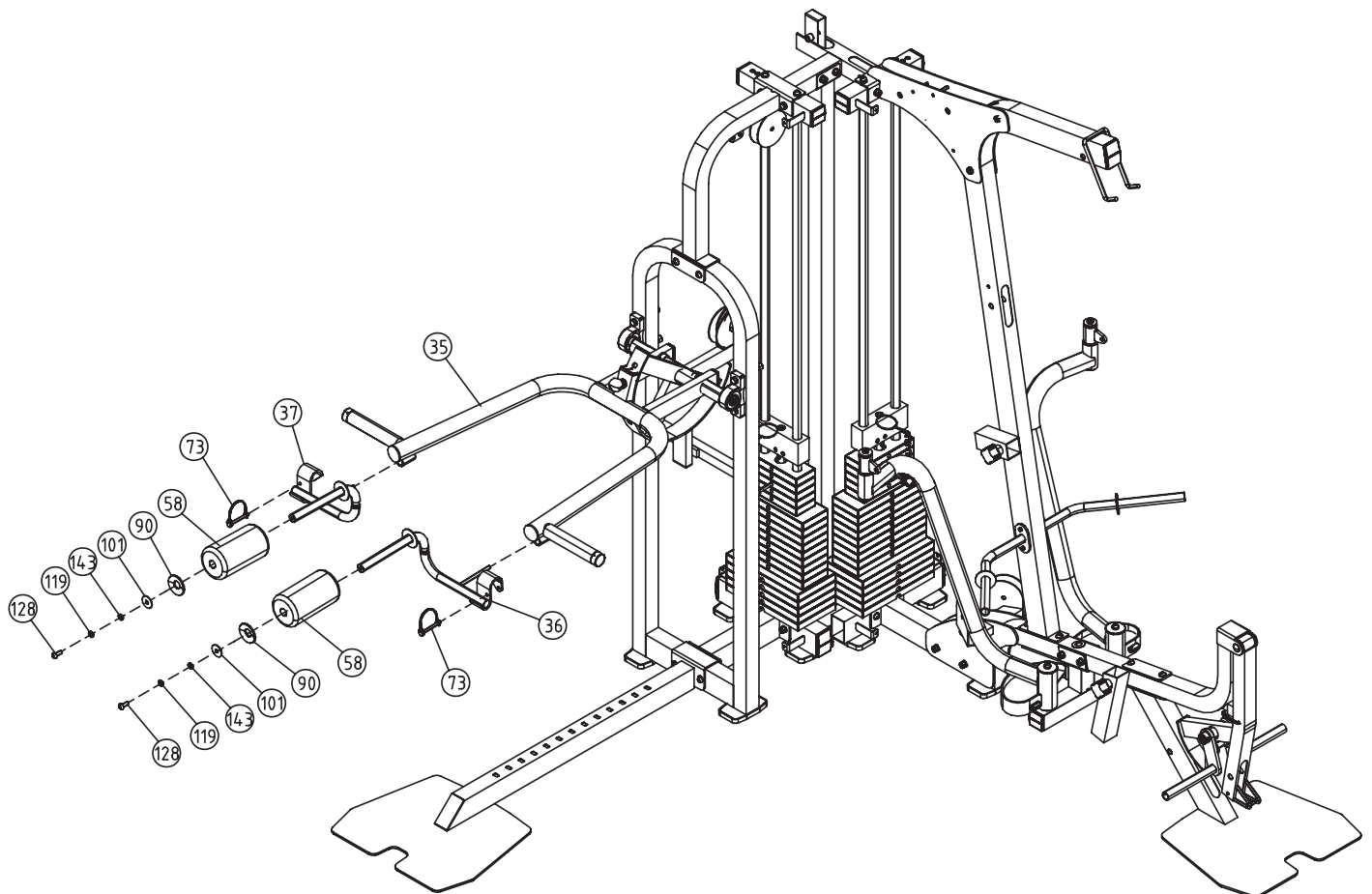

Step 16

Attach Back Pad (51) to Back Pad Adjustment Bracket (28) using two Washers (143) and two Bolts (127).

Attach Seat Pad (50) to Seat Pad Support (27) using two Washers (143) and two Allen Bolts (127).

Slide both assemblies into receptacles as shown in *Figure 16*.

Figure 16

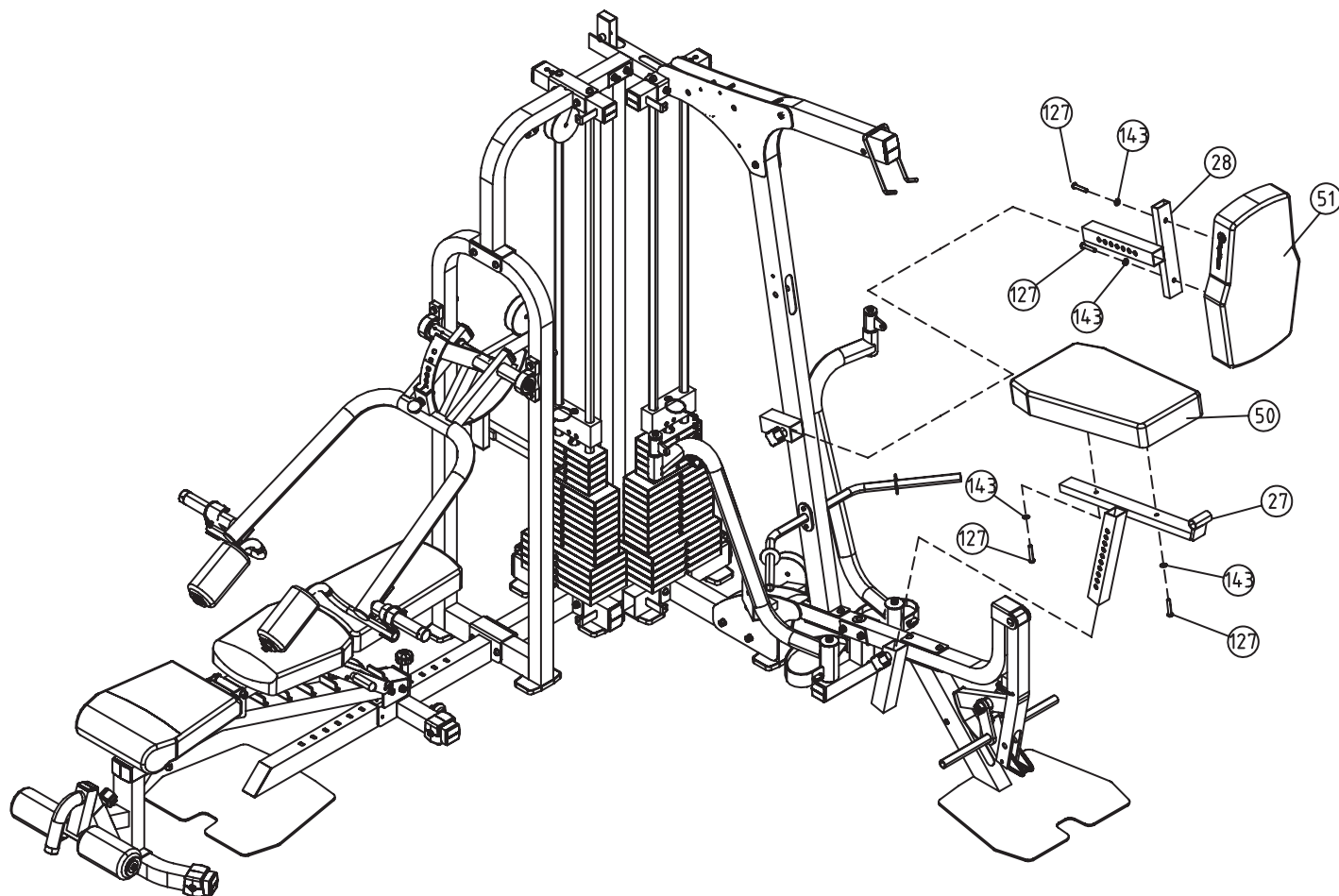

Step 17

Slide two Upholstered Roller Pads (58) onto Foam Frames and secure using two Big Plugs (89).

Slide the Long Foam Tube (34) through the hole in Seat Pad Support. Next, slide two Plastic Washers (90), two Upholstered Roller Pads (58), and two Big Plugs (89) onto each end of Long Foam Tube (34).

Next, slide two Upholstered Roller Pads (58) onto each side of Leg Hold Frames and secure using two Big Plugs (89).

Figure 17

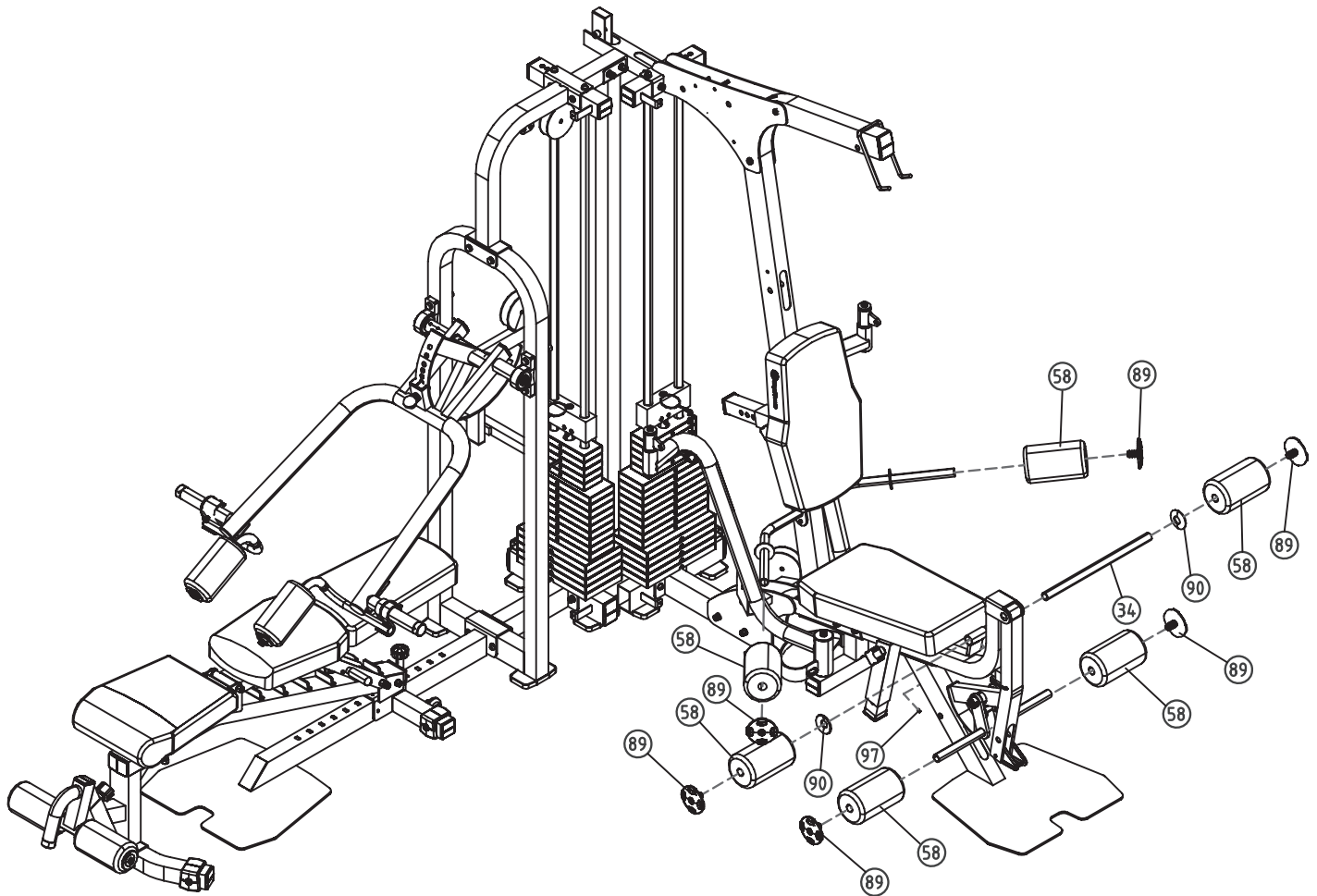

Step 18

Note: Stretch all cables out completely and make sure all twisting is removed before installing.

Install Lat Cable (110) as detailed in *Figure 18*. Follow dotted lines to identify exact location of pulleys. See Page 43 "Cable View" for more detail.

Start by threading cable end into Top Plate (55).

You will need the following for installation:

- | | |
|-------------------------------------|---------------------|
| Pulley (57) - Qty. 7 | Bolt (134) - Qty. 2 |
| Cable (110) - Qty. 1 | Bolt (135) - Qty. 1 |
| Nut (144) - Qty. 7 | Bolt (136) - Qty. 1 |
| Long Pulley Spacer (123) - Qty. 4 | Bolt (137) - Qty. 1 |
| Longer Pulley Spacer (121) - Qty. 4 | Bolt (141) - Qty. 2 |
| Washer (143) - Qty. 14 | |

Figure 18

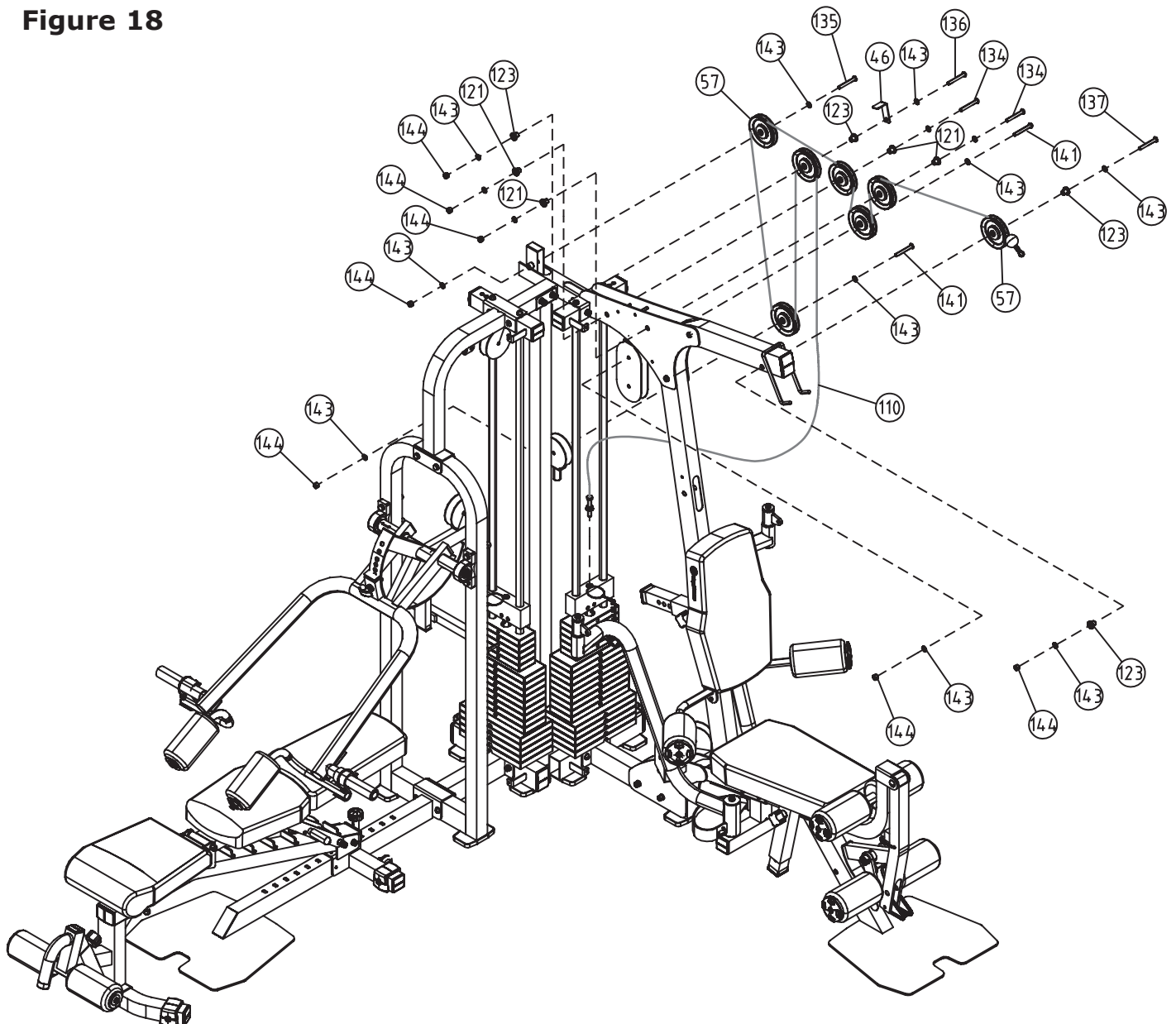

Step 19

Note: This step is only used if you **do not** have the Leg Press 3 attachment. If you do have Leg Press 3 attachment, please follow instructions located in that manual. Use the Cable Adapter (124) in place of the pulley.

Note: Stretch all cables out completely and make sure all twisting is removed before installing.

Install Leg Press Cable Substitute (113) as detailed in *Figure 19*. Follow dotted lines to identify exact location of pulleys.

You will need the following for installation:

Cable Adapter (124) - Qty. 1

Cable (113) - Qty. 1

Washers (143) - Qty. 2

Nut (144) - Qty. 1

Pulley Bracket with Shaft (33) Qty. 1

Bolt (139) - Qty. 1

Nylon Locknut (143) - Qty. 1

Figure 19

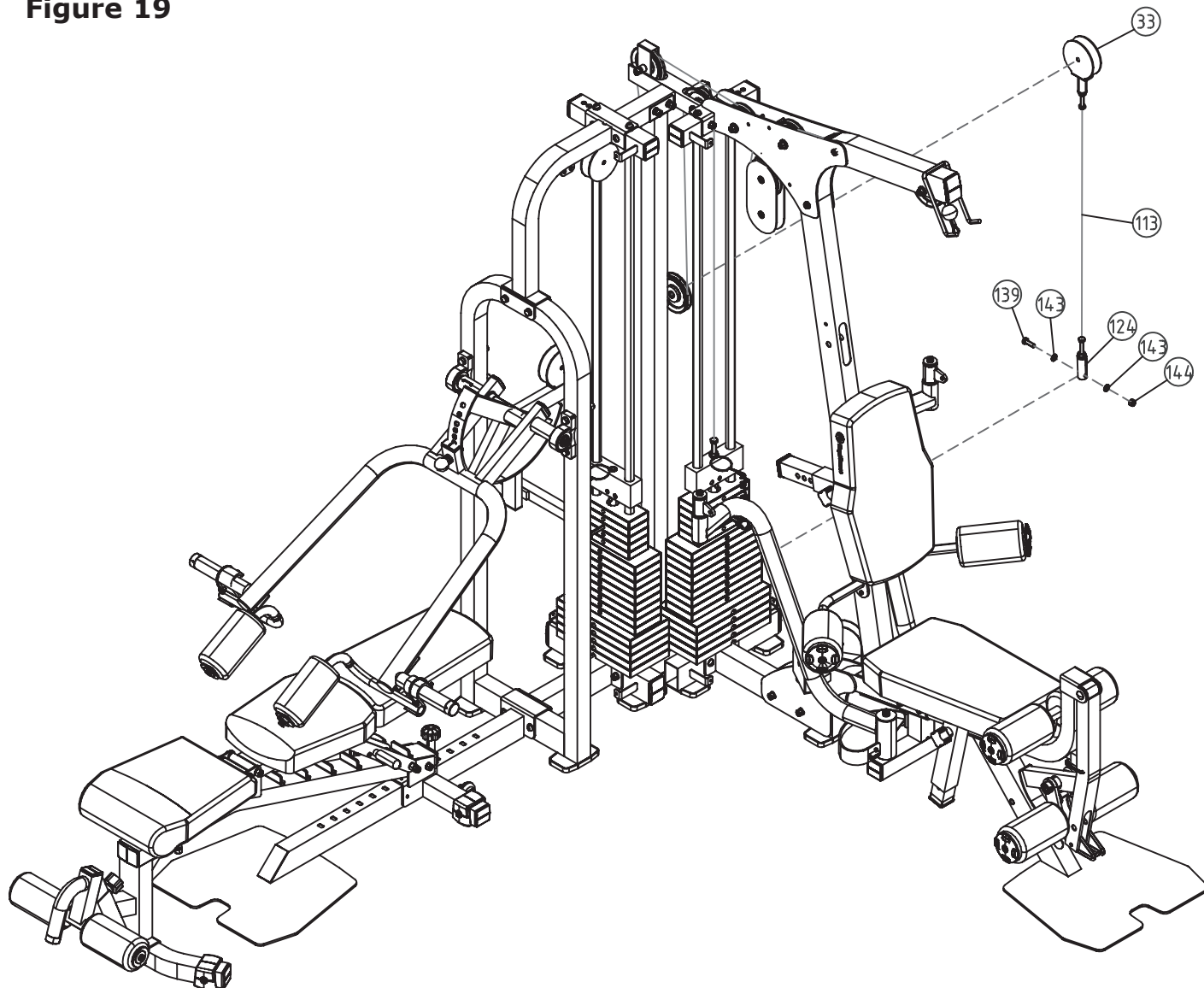

Step 20

Note: Stretch all cables out completely and make sure all twisting is removed before installing.

Install Low Row Cable (111) as detailed in *Figure 20*. Follow dotted lines to identify exact location of pulleys. See *Page 43 "Cable View"* for more detail.

Start by installing cable under the pulley at Leg Extension location.

You will need the following for installation:

- | | |
|--------------------------------------|------------------------|
| Pulley (57) - Qty. 6 | Bolt (134) - Qty. 1 |
| Cable (111) - Qty. 1 | Bolt (136) - Qty. 1 |
| Nut (144) - Qty. 6 | Bolt (137) - Qty. 1 |
| Long Pulley Spacer (123) - Qty. 4 | Bolt (138) - Qty. 1 |
| Longer Pulley Spacer (121) - Qty. 2 | Bolt (141) - Qty. 2 |
| Short Pulley Spacer (122) - Qty. 2 | Washer (143) - Qty. 12 |
| Cable Retainer Bracket (46) - Qty. 1 | |

Figure 20

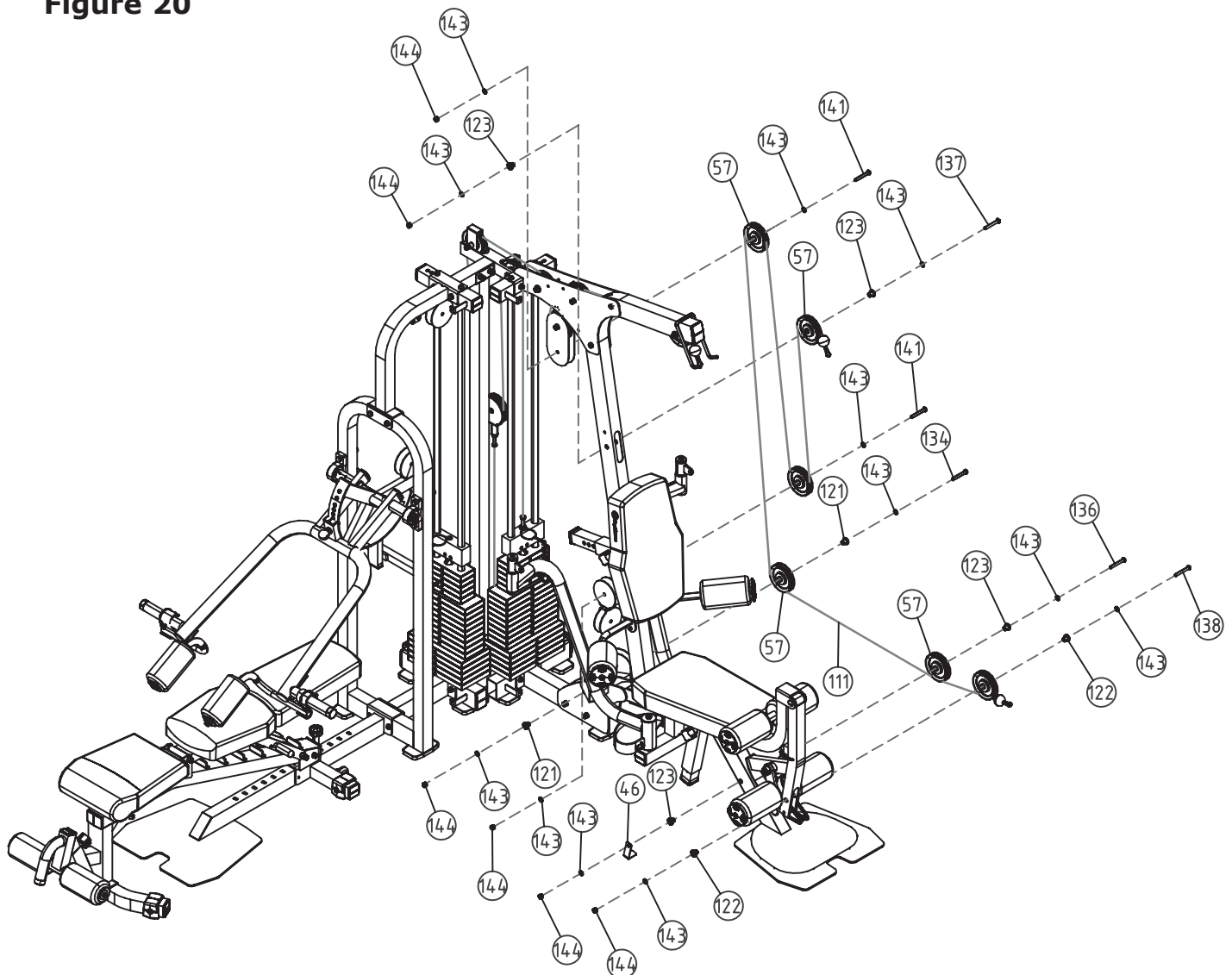

Step 21

Note: Stretch all cables out completely and make sure all twisting is removed before installing.

Install Pec Dec Cable (112) as detailed in *Figure 21*. Follow dotted lines to identify exact location of pulleys.

See Page 43 "Cable View" for more detail.

You will need the following for installation:

Cable (112) - Qty. 1

Pulley (57) - Qty. 3

Bolt (141) - Qty. 3

Washer (143) - Qty. 6

Nut (144) - Qty. 3

Philips Screw (103) - Qty. 2

Figure 21

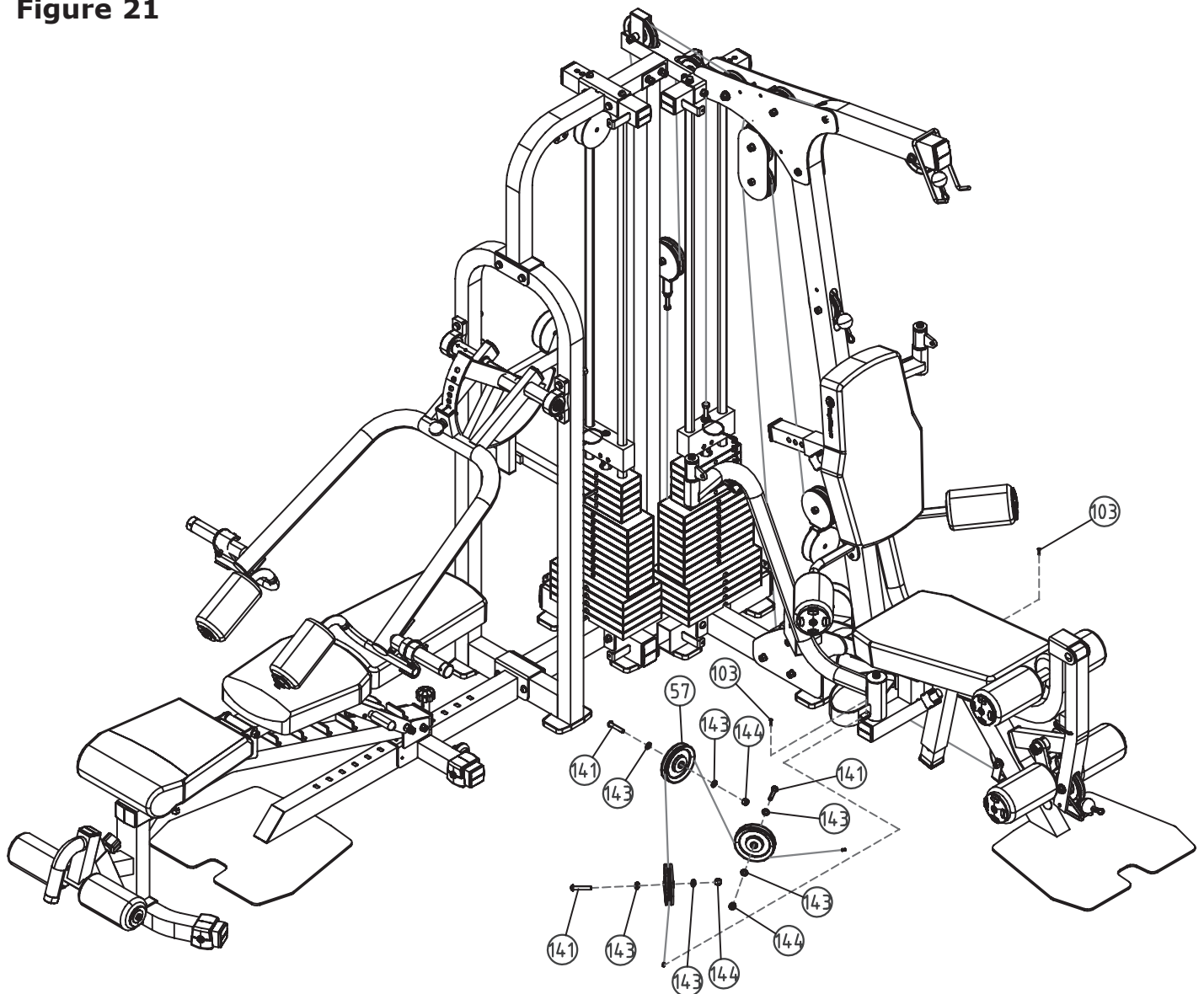

Step 22

Note: Stretch all cables out completely and make sure all twisting is removed before installing.

Install Long Chest Cable (114) as detailed in *Figure 22*. Follow dotted lines to identify exact location of pulleys. See *Page 43 "Cable View"* for more detail.

Start by installing cable into the "Press Station" weight stack.

You will need the following for installation:

Pulley (57) - Qty. 2

Cable (114) - Qty. 1

Nut (144) - Qty. 3

Washer (134) - Qty. 4

Bolt (141) - Qty. 3

Figure 22

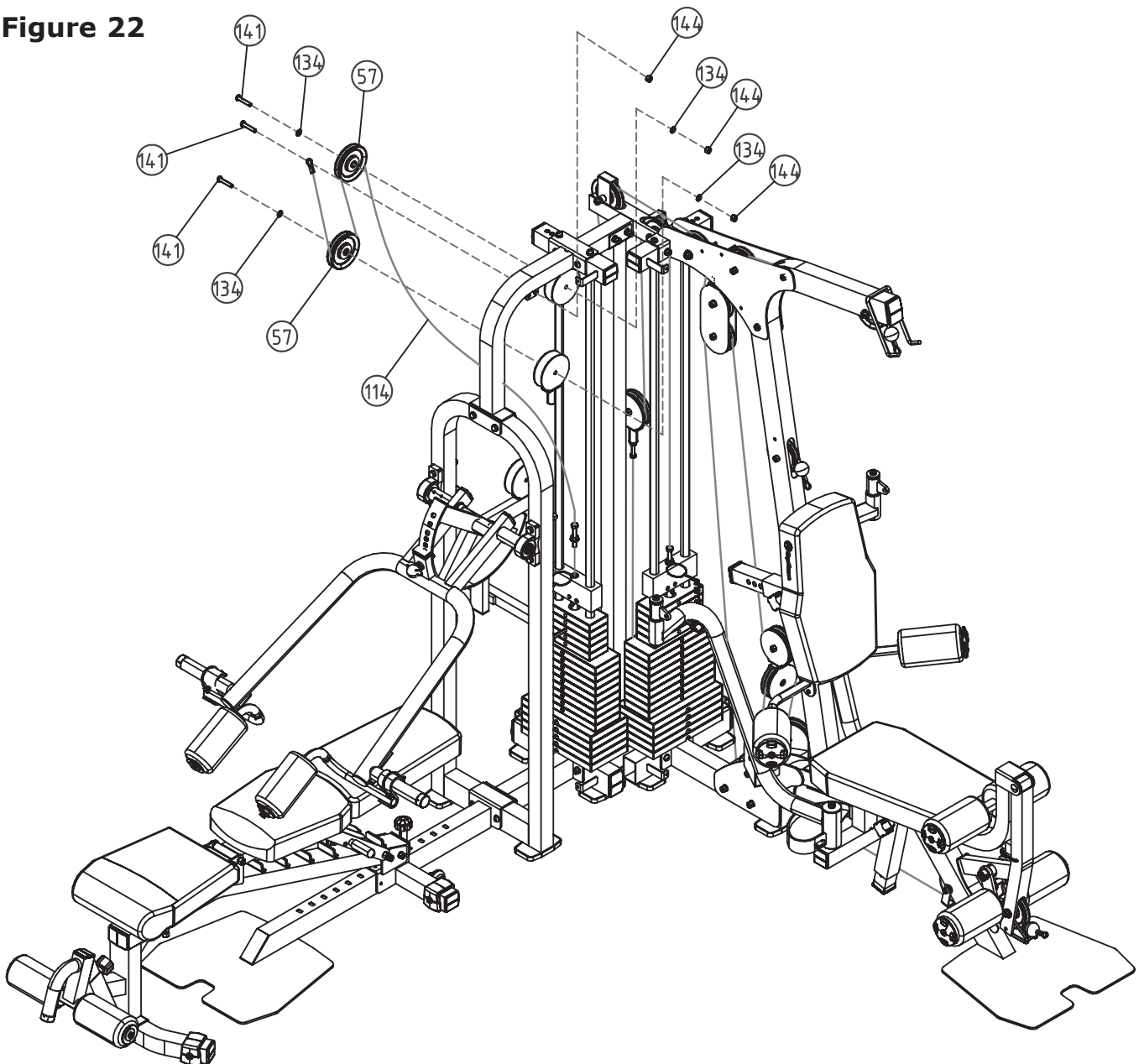

Step 23

Note: Stretch all cables out completely and make sure all twisting is removed before installing.

Install Short Chest Cable (115) as detailed in *Figure 23*. Follow dotted lines to identify exact location of pulleys. See *Page 43 "Cable View"* for more detail.

Start by threading the cable into the floating pulley bracket.

You will need the following for installation:

Pulley (57) - Qty. 1

Cable (115) - Qty. 1

Nut (144) - Qty. 2

Washer (134) - Qty. 2

Bolt (141) - Qty. 2

Figure 23

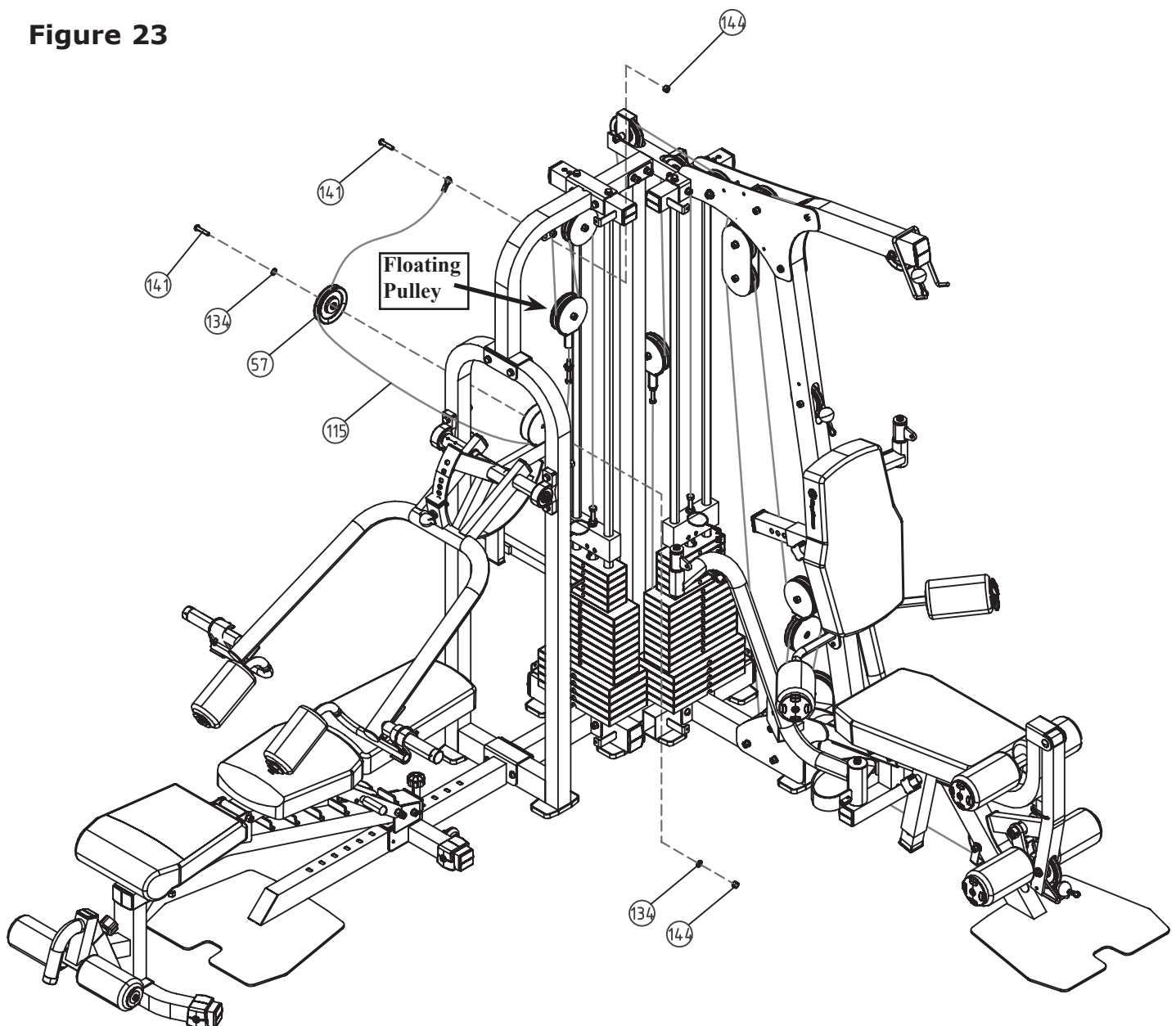

Step 24

Connect Long Lat Bar (43) to the Lat Cable (110) using two Gear Hooks (87) and Short Chain (88).

Connect Ab Strap (60) or Lat Strap (61) to Low Row Cable (111) using one Gear Hook (87).

Connect Short Lat Bar (44) or Ankle Strap (62) to Low Row Cable (111) using two Gear Hooks (87) and Long Chain (116).

Figure 24

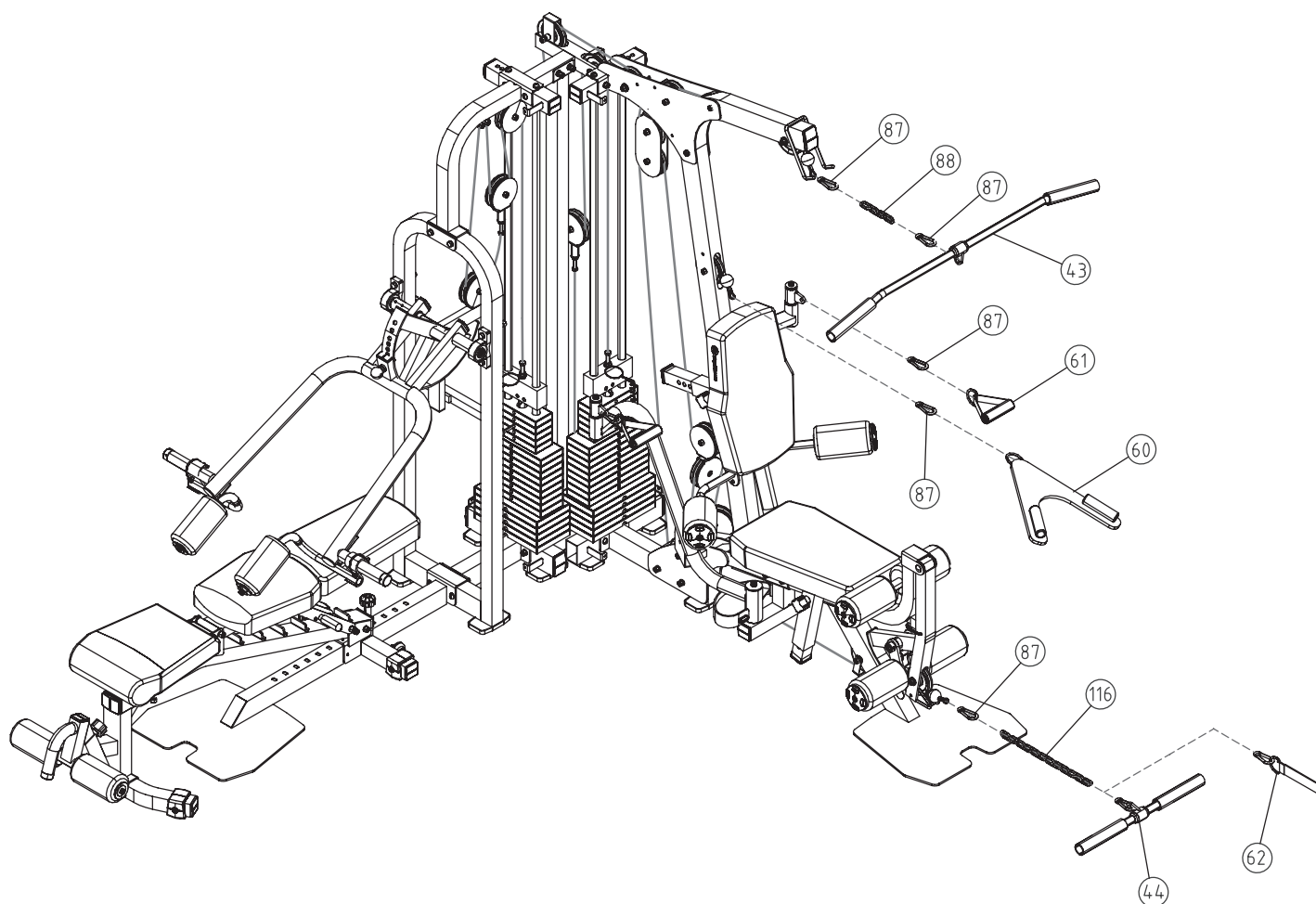

Step 25

Install Weight Shrouds (41) to the left and right side of the weight stacks using four Washers (117) and four Bolts (98).

Install Weight Shroud (42) to the center of both weight stacks and secure using four Washers (117) and four Bolts (98).

Figure 25

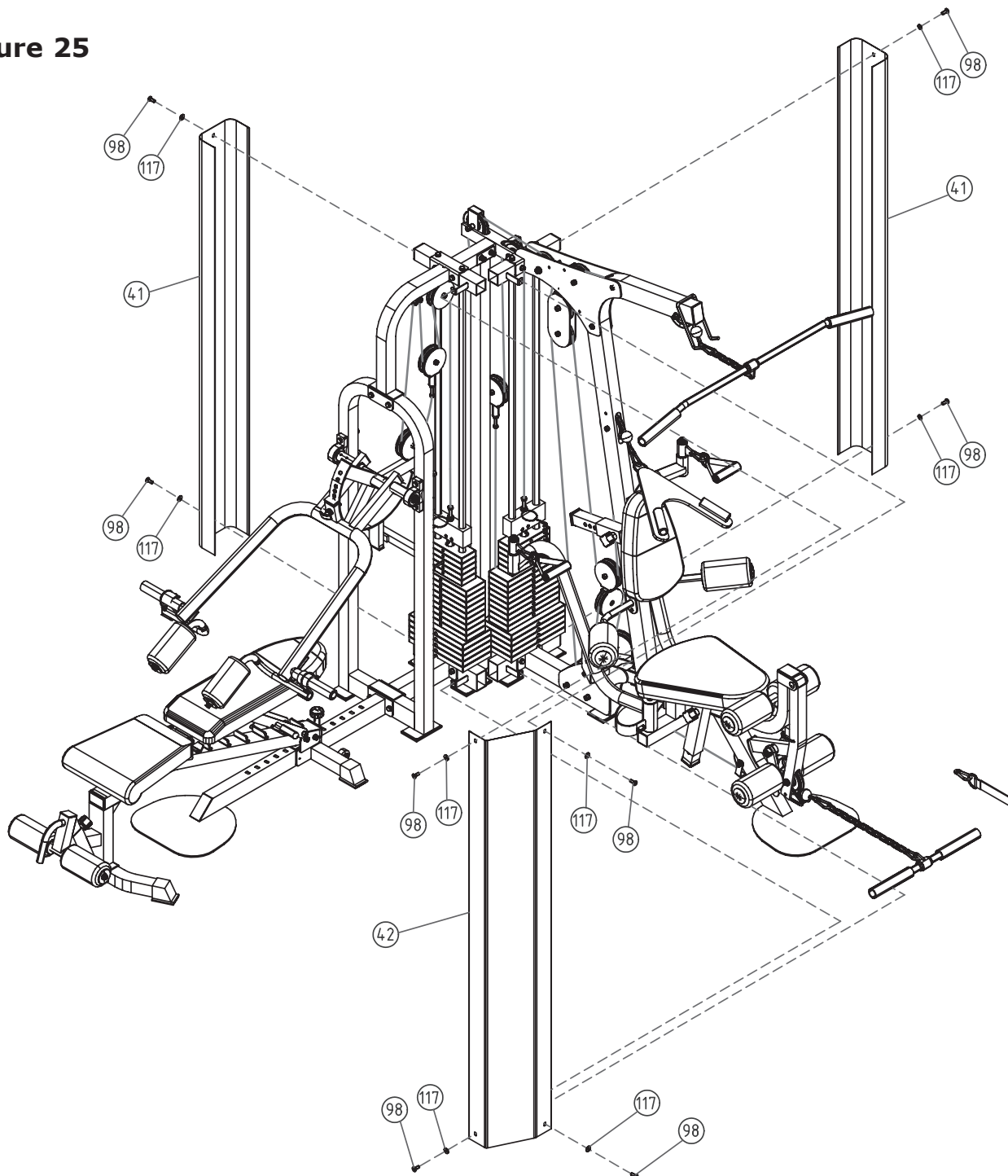

Note: Tighten all hardware securely.

Congratulations!

You have completed the assembly of your new KF-2050.

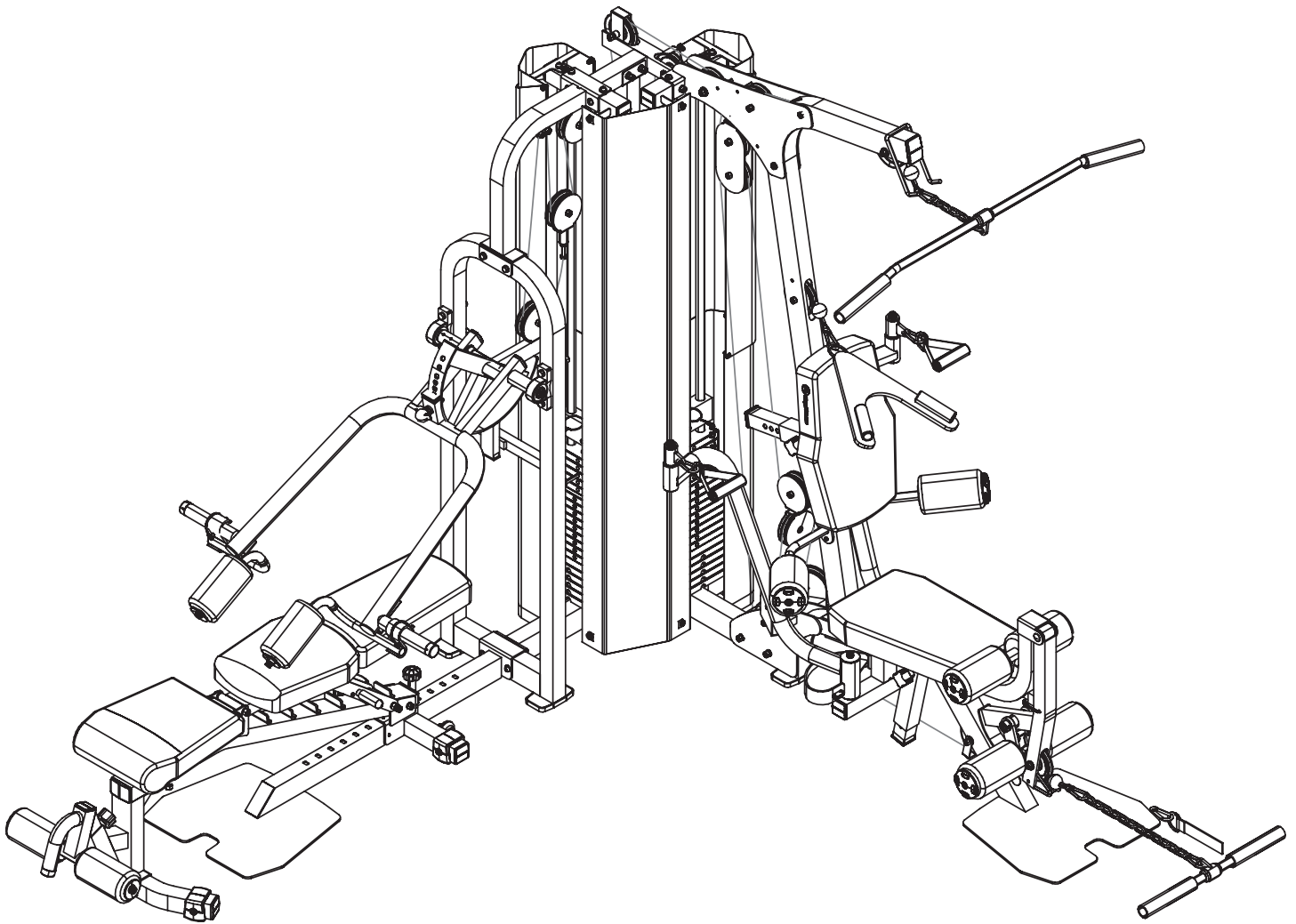

Weight Ratios

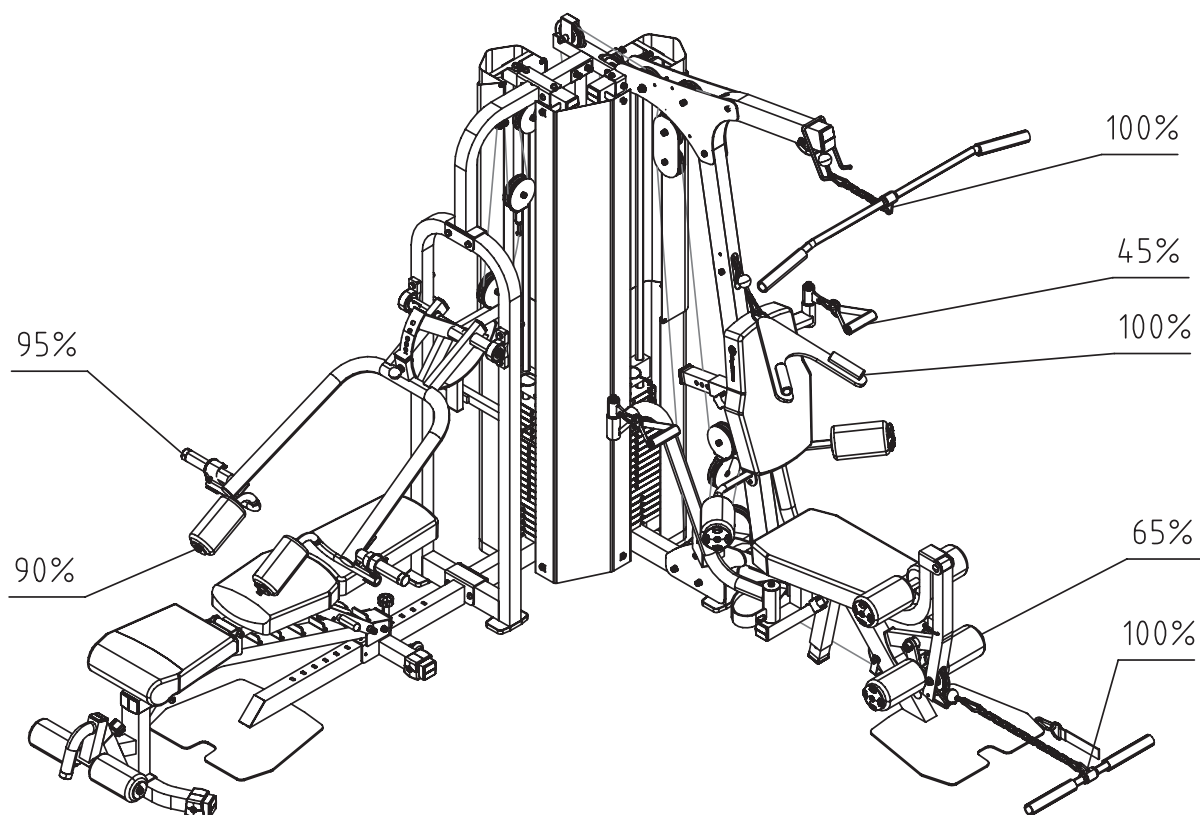

	100%	95%	90%	65%	45%
1	10	9.5	9	6.5	4.5
2	15	14	13.5	10	7
3	20	19	18	13	9
4	25	24	23	16	11
5	30	29	27	20	14
6	35	33	32	23	16
7	45	43	41	29	20
8	55	52	50	36	25
9	65	62	59	42	29
10	75	71	68	49	34
11	85	81	77	55	38
12	95	90	86	62	43
13	105	100	95	68	47
14	115	110	104	75	52
15	125	119	113	81	56
16	140	133	126	91	63
17	155	147	140	101	70
18	170	162	153	111	76
19	185	176	167	120	83
20	200	190	180	130	90

KF2060

Weight Stack Sticker Placement

Your new POWER SYSTEM unit can be purchased with either a 200 LB or 250 LB weight stack. Depending on which weight stack you have purchased will determine which weight stack sticker numbers will be used.

The weight stack images below show which weight stack sticker numbers are to be used on your weight stack. Please note that these stickers should not be put on until the entire unit has been assembled and all bolts and nuts have been tightened.

200 LB Stack

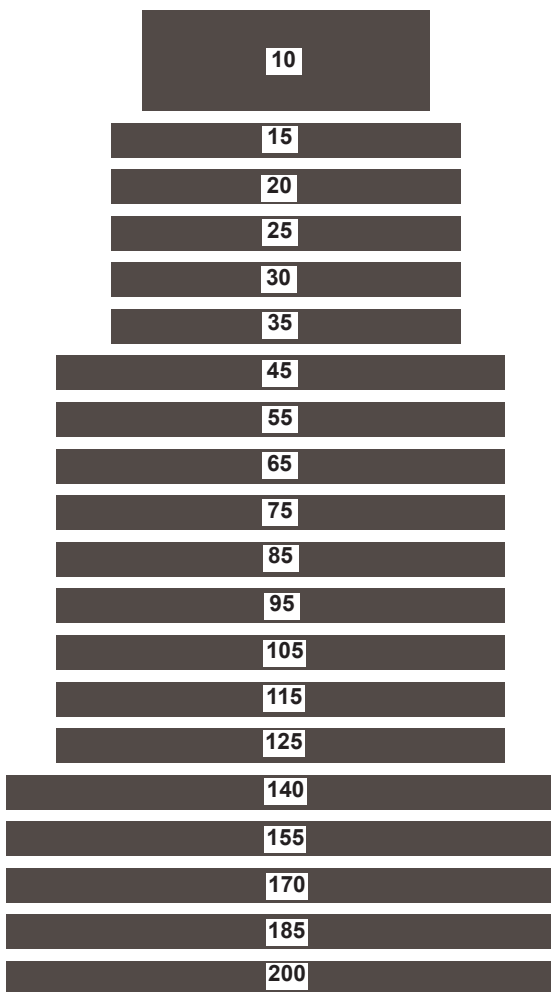

250 LB Stack

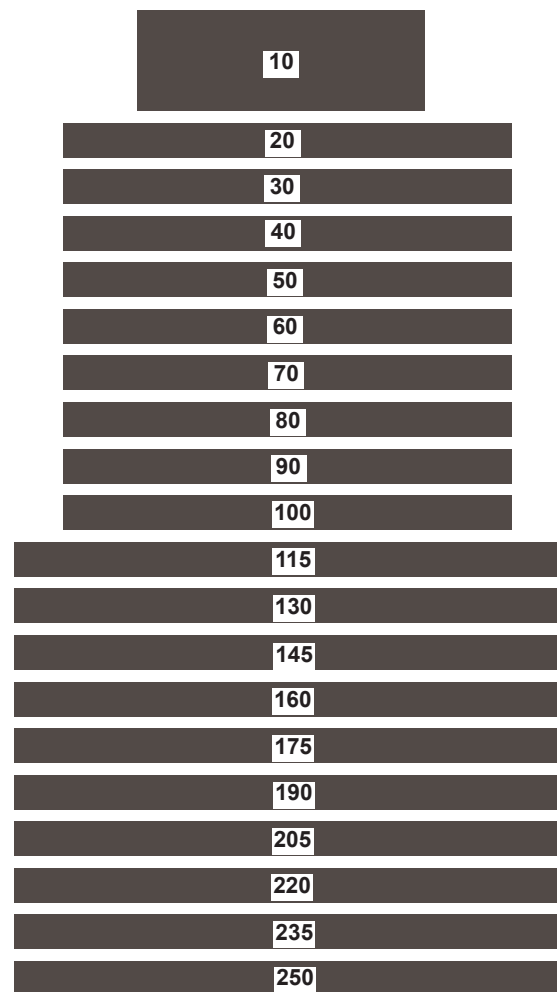

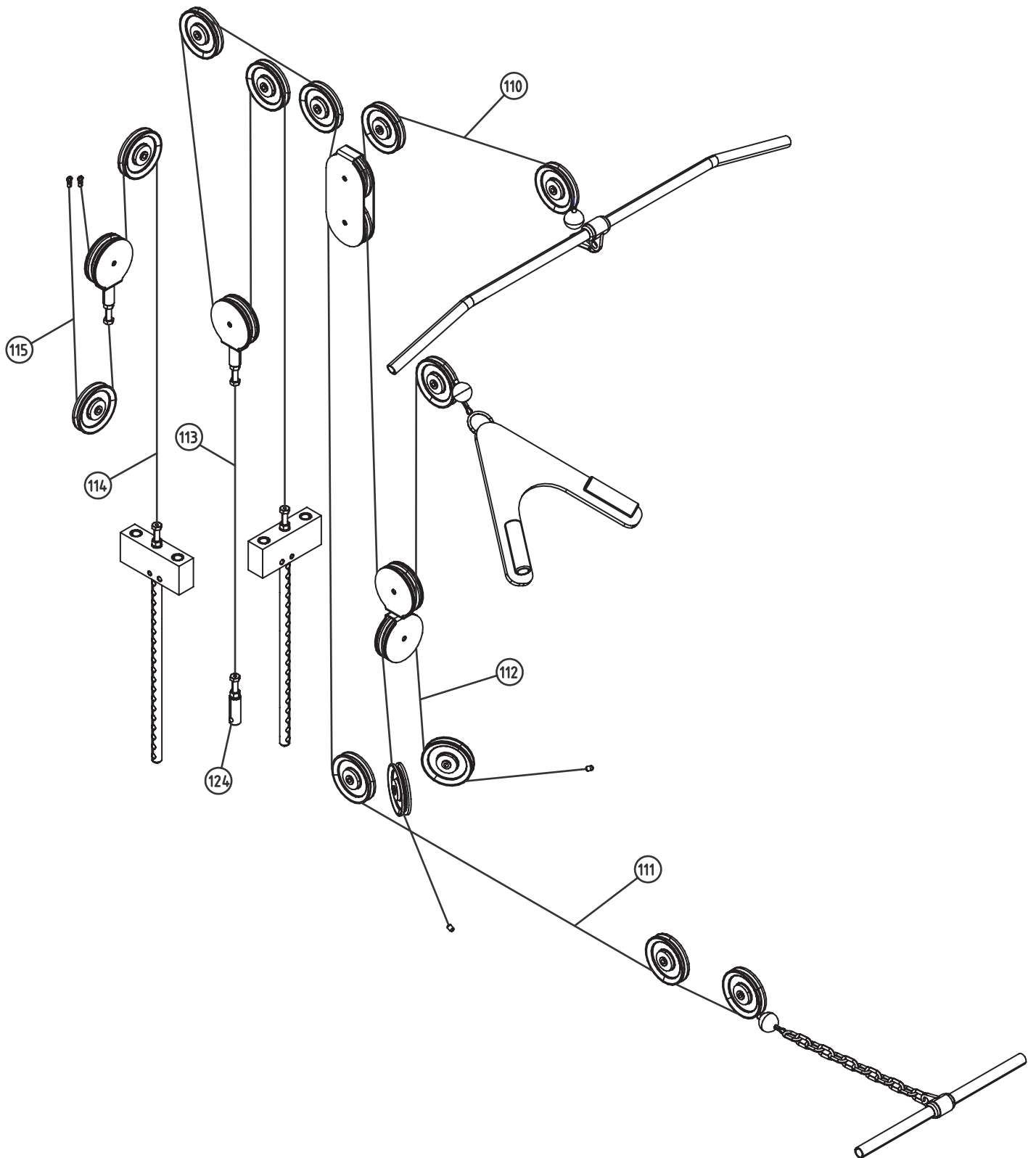

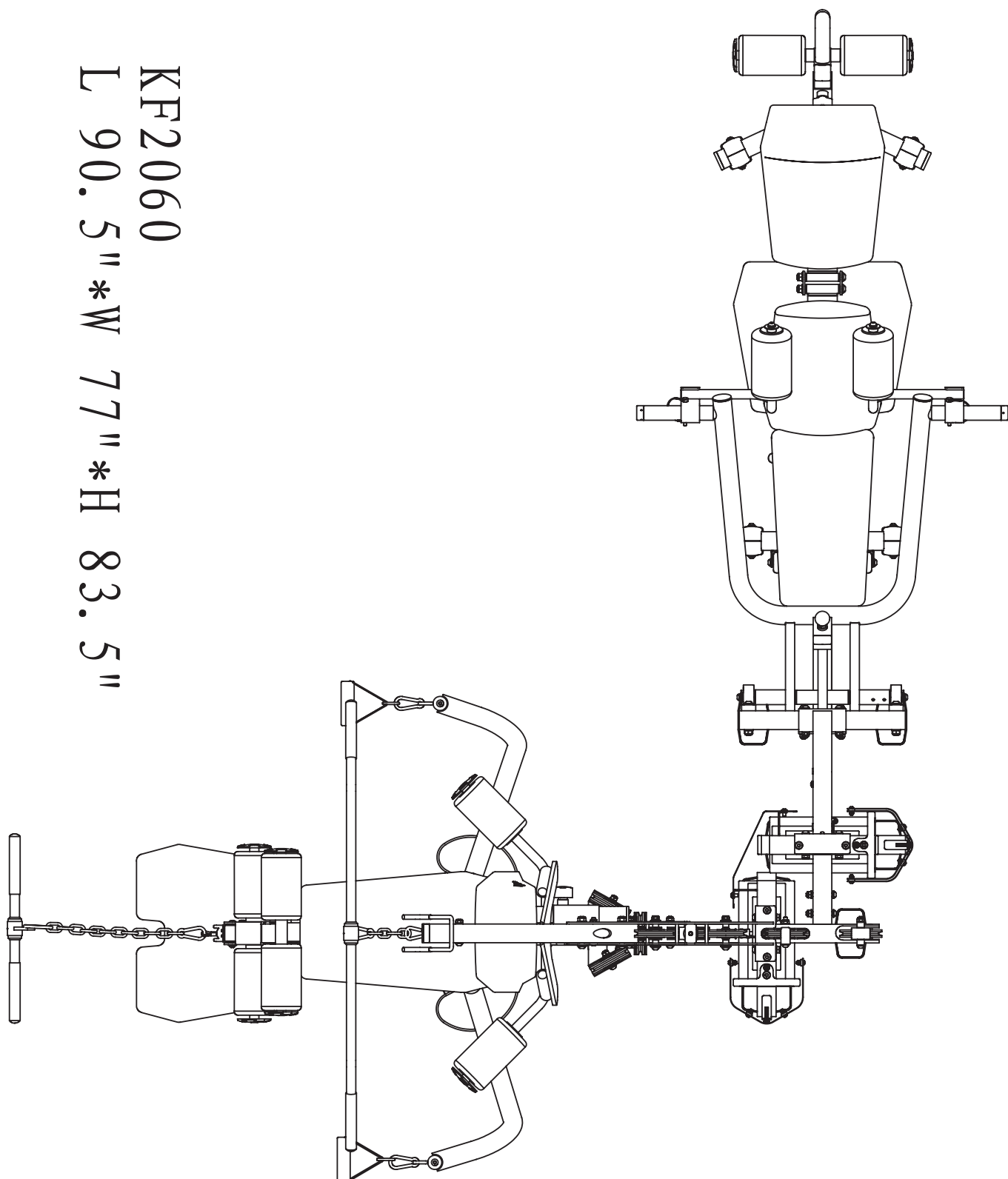

KF2060
L 90.5" * W 77" * H 83.5"

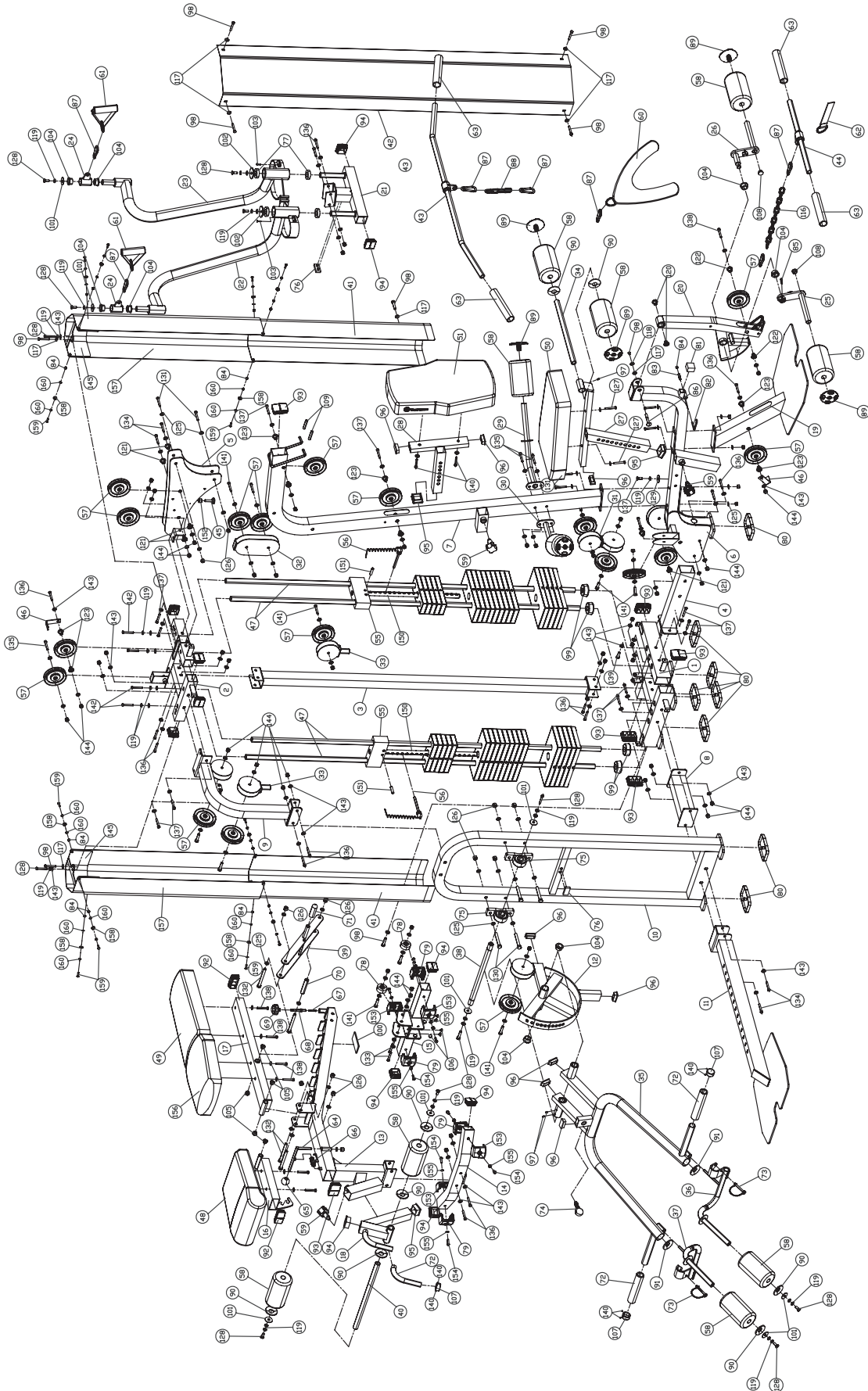

KEYS FITNESS PRODUCTS, L.P. LIFETIME WARRANTY



This Warranty applies in the United States and Canada to products manufactured or distributed by Keys Fitness Products, LP ("Keys") under the KEYS brand name. The warranty is non-transferable and valid only to the original purchaser.

Keys warrants that the Product you have purchased for non-commercial, personal, family, or household use from Keys or from an authorized Keys reseller is free from defects in materials or workmanship under normal use during the warranty period. Your sales receipt, showing the date of purchase of the Product, is your proof of purchase. This warranty only extends to you, the original purchaser. It is not transferable to anyone who subsequently purchases or acquires the Product from you. This Warranty becomes **VALID ONLY** if the product is purchased through a Keys Fitness authorized dealer unless otherwise authorized by Keys Fitness in writing and must be assembled / installed according to the instructions included with the Product.

In a light institutional setting, Keys will extend a one year limited warranty to the original purchaser.

During the warranty period Keys will repair or replace (at Keys' option) the product if it becomes defective, malfunctions, or otherwise fails to conform with this Warranty under normal use. In repairing the Product, Keys may replace defective parts with new or, at the option of Keys, serviceable used parts that are equivalent to new parts in performance. All exchanged parts and Products replaced under this warranty will become the property of Keys. Keys reserves the right to change manufacturers of any part to cover any existing warranty.

This warranty **DOES NOT COVER** shipping charges, export taxes, custom duties and taxes, or any other charges associated with transportation of the parts or Product. To obtain warranty service, you must contact a Keys authorized retailer, service technician or Keys Fitness at our phone number located in this manual. Any parts determined to be defective must be returned to Keys to obtain warranty service. You must prepay any shipping charges, export taxes, custom duties and taxes, or any other charges associated with transportation of the parts or Product. In addition, you are responsible for insuring any parts or Product shipped or returned. You assume the risk of loss during shipment. You must present Keys with proof-of-purchase documents (including the date of purchase). Any evidence of alteration, erasure or forgery of proof-of-purchase documents will be cause to void this Warranty.

This Warranty does not extend to any product not purchased from Keys or from an authorized Keys reseller. This Limited Warranty does not extend to any Product that has been damaged or rendered defective; (a) as a result of accident, misuse, or abuse; (b) by the use of parts not manufactured or sold by Keys; (c) by modification of the Product; (d) operation on incorrect power supplies; or (e) as a result of service by anyone other than Keys, or an authorized Keys warranty service provider. Product on which the serial number has been defaced or removed is not eligible for warranty service. Should any Product submitted for warranty service be found ineligible, an estimate of repair cost will be furnished and the repair will be made if requested by you upon Keys' receipt of payment or acceptable arrangements for payment.

EXCEPT AS EXPRESSLY SET FORTH IN THIS WARRANTY, KEYS MAKES NO OTHER WARRANTIES, EXPRESSED OR IMPLIED, INCLUDING ANY IMPLIED WARRANTIES OF MERCHANTABILITY AND FITNESS FOR A PARTICULAR PURPOSE. KEYS EXPRESSLY DISCLAIMS ALL WARRANTIES NOT STATED IN THIS LIMITED WARRANTY. ANY IMPLIED WARRANTIES THAT MAY BE IMPOSED BY LAW ARE LIMITED TO THE TERMS OF THIS LIMITED WARRANTY. NEITHER KEYS NOR ANY OF ITS AFFILIATES SHALL BE RESPONSIBLE FOR INCIDENTAL OR CONSEQUENTIAL DAMAGES. SOME STATES DO NOT ALLOW LIMITATIONS ON HOW LONG AN IMPLIED WARRANTY LASTS OR THE EXCLUSION OR LIMITATION OF INCIDENTAL OR CONSEQUENTIAL DAMAGES, SO THE ABOVE LIMITATIONS OR EXCLUSION MAY NOT APPLY TO YOU. This Limited Warranty gives you specific legal rights and you may also have other rights that may vary from state to state. This is the only express warranty applicable to Keys-branded products. Keys neither assumes nor authorizes anyone to assume for it any other express warranty.

PLEASE SEND IN THE INCLUDED WARRANTY CARD OR REGISTER ON-LINE AT www.keysfitness.com WITHIN TEN (10) DAYS OF PURCHASE TO REGISTER YOUR UNIT WITH KEYS FITNESS PRODUCTS, LP. MAIL WARRANTY CARD TO: KEYS FITNESS PRODUCTS, PO BOX 551239, DALLAS, TX 75355



Keys Fitness Products, L.P.
4009 Distribution Drive, Suite 250
Garland, Texas 75041
Customer Service: 1-888-380-0482